

# NAMDIATREAM Dissemination Booklet

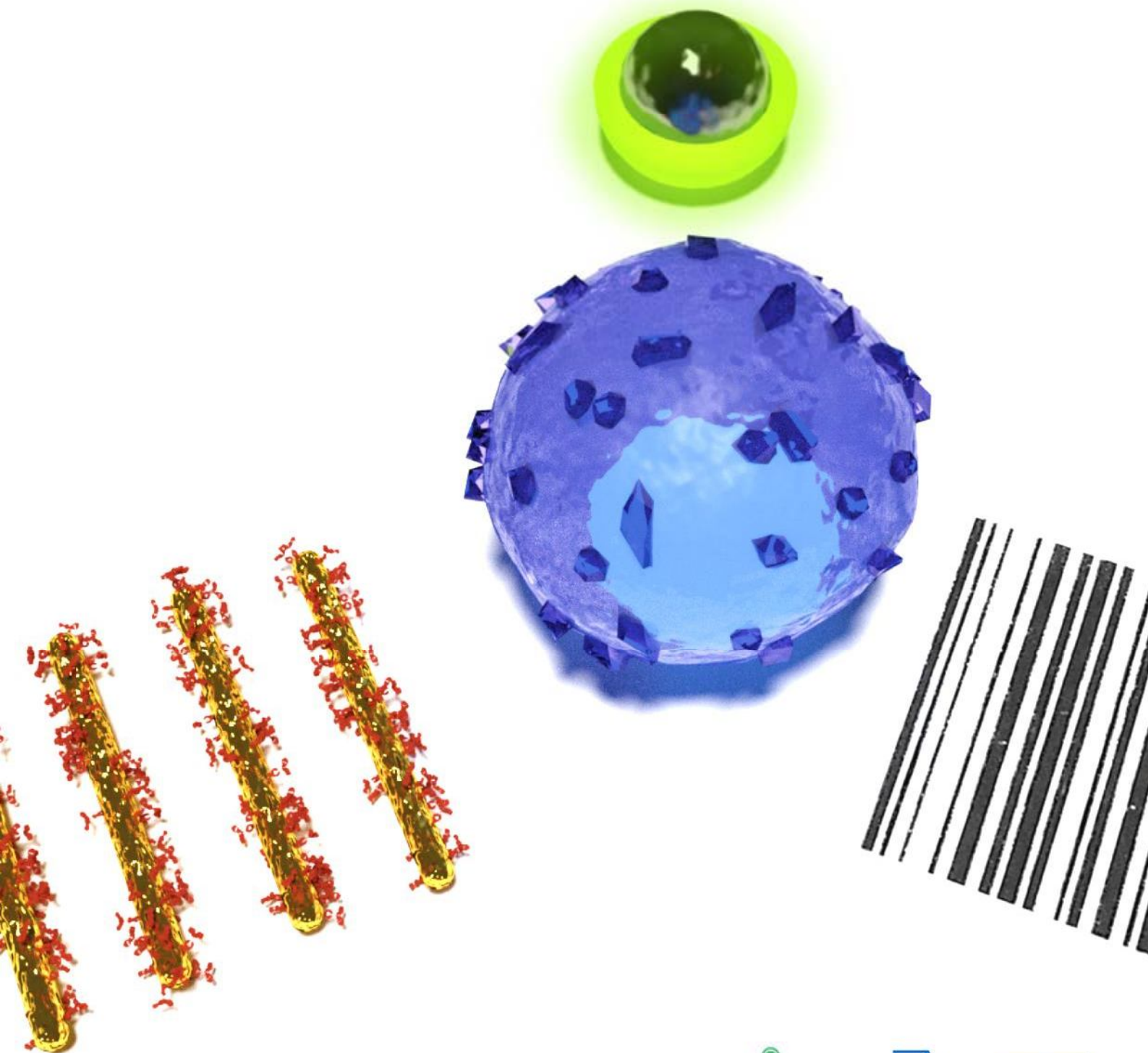

[www.namdiatream.eu](http://www.namdiatream.eu)



© Board of Trinity College Dublin, 2014. All rights reserved.

Published by Trinity College Dublin.

Editors: Adriele Prina-Mello and Yuri Volkov,  
School of Medicine, Trinity College Dublin.

ISBN: 978-1-871408-93-5



# Table of Contents

<b>Preface</b> .....	<b>1</b>
<b>Workshop at the World Molecular Imaging Congress 2012</b> .....	<b>4</b>
<i>Overview of Workshop</i> .....	<i>5</i>
<b>Presentation Highlights</b> .....	<b>5</b>
<b>Outcomes</b> .....	<b>7</b>
<b>Program of the Workshop at the World Molecular Imaging Congress 2012</b> .....	<b>8</b>
<i>Presentation Abstracts</i> .....	<i>9</i>
<b>(I) Advances in imaging and diagnostics using nanotechnological tools</b> .....	<b>9</b>
Nanotechnology in diagnostic monitoring and treatment of cancer: Advances in molecular imaging .....	10
Harmonic nanoparticles for biolabelling .....	12
Plasmonic magnetic detection for advanced clinical diagnostics .....	13
Quantum dots as fluorescent probes for advanced imaging .....	14
Nanotechnology in advanced imaging .....	15
Evolving flow cytometry from cellular to sub-cellular analysis .....	16
The use of NanoSight NTA to measure exosomes and other nanosized biological particles .....	17
<b>(II) Advances in imaging and theranostics using nanotechnological tools</b> .....	<b>18</b>
MULTIFUN: Project highlights .....	19
Magnetic nanoparticles for advanced MRI imaging and hyperthermia .....	20
Functionalization of magnetic nanoparticles for theranostics .....	21
Nanoparticles and advanced MRI detection and imaging .....	22
Clinical use of magnetic nanoparticles .....	24
New devices based on advanced imaging .....	25
<b>(III) Cluster: Targeted nanopharmaceuticals and diagnostics</b> .....	<b>26</b>
Overview of targeted nanopharmaceuticals and diagnostics cluster activity .....	27
Folate-based nanobiodevices for integrated diagnosis/therapy targeting chronic inflammatory diseases .....	28
SaveMe: A modular active nano-platform for advanced cancer management — Core nanosystems, tumour targeting and penetration, molecular imaging and degradome based therapy .....	29
3MICRON: Multimodality microballoons .....	30
<b>(IV) Imaging cell and tissue interaction with nanomaterials</b> .....	<b>31</b>
Advanced models for imaging cancer .....	32
Nanotoxicology implications in Nanomedicine: unanswered questions and future directions .....	33
Imaging cell and tissue interaction with nanomaterials: From 2D to 3D models .....	34
Raman spectroscopy in clinical diagnostics .....	35
High content screening of cellular response to nanomaterials interaction as imaging and decision-making tool .....	36

<b>Winter School at Villars-sur-Ollon (2013)</b> .....	<b>37</b>
<i>Overview of Winter School</i> .....	<i>38</i>
<b>Presentation Highlights</b> .....	<b>38</b>
<b>Outcomes</b> .....	<b>39</b>
<b>Program of the Winter School</b> .....	<b>40</b>
<i>Presentation Abstracts</i> .....	<i>41</i>
<b>Oral Presentations</b> .....	<b>41</b>
Nanotechnological tools for diagnostics and therapy: Benefits and risks .....	42
Lipidots®: Translating innovation in nanocarriers from lab to pharma – How the European Technology Platform on Nanomedicine can help you .....	43
Nanomaterials and human respiratory epithelia: Old friends and new therapeutic concepts .....	44
Single molecule imaging in the nucleus to dissect transcription regulation .....	45
Optical coherent imaging from tissue to molecule .....	46
Magnetic nanoparticle detection: From homogeneous bioassays to imaging .....	47
Polymeric nanoparticles for drug delivery and targeting purposes .....	48
Denting status quos in diagnostics and therapeutics .....	49
The technology transfer processes: Practical approaches within the NAMDIATREAM project .....	50
<b>Poster Presentations</b> .....	<b>51</b>
Co-nanorod heterostructures .....	52
Toward a low temperature synthesis of monodisperse bismuth ferrite nanocrystals .....	52
On the Synthesis of Functionalized Bismuth Ferrite Nanocrystals .....	53
Implementation and assessment of nonlinear optical excitation in a commercial flow cytometer .....	53
Methotrexate-modified iron oxide nanoparticles: Multifunctional nano-theragnostics for MRI and drug delivery .....	54
Functionalization of nanoparticles with small targeting molecules for cancer diagnosis and imaging .....	55
Detection of magnetic nanowires using Yoke-shaped MgO-barrier magnetic tunnel junction (TMR) and GMR sensors: Towards a magnetic cytometer .....	56
Homogenous bioassay based on specifically labeled magnetic nanoparticles in a rotating magnetic field .....	57
Homogeneous biosensor protein detection by monitoring changes in the rotational dynamics of nickel nanorods .....	58
Developing multiphoton multipurpose characterization system for biomaging materials .....	59
Nanotechnological Toolkits for the Multimodal Detection and Monitoring of Disease (NAMDIATREAM) .....	60
Application of novel diagnostic nanoprobe for immunolabelling of breast and lung cancer biomarkers .....	60
Substrate optimization of a nanostructured plasmonic transfection device .....	61
Immunoassays development for the quantification of cancer biomarkers .....	62
Kv10.1 overexpression results in cell-cell adhesion deficits and increased cell motility .....	62
Validation of tumour-specific fluorescent nanoprobe in a metastatic mouse breast tumour model .....	63
New theranostic application of second harmonic BFO nanoparticles as phototherapy tool .....	63
Bioimaging with rationally designed NIR-fluorescent nanosensors .....	64
High-Speed Tracking of Murine Cardiac Stem Cells by Harmonic Nanodoublers .....	65
Nanotoxicology screening of coated iron oxide nanoparticles: for the selection of lead candidate for theranostic applications .....	66
Imaging techniques for pancreatic ductal adenocarcinoma (PDAC) diagnostics based on Eag1 voltage gated potassium channel .....	67

<b>Workshops at Euronano Forum 2013.....</b>	<b>68</b>
<i>Overview of Conference and Workshops.....</i>	<i>69</i>
<i>Nanomedicine at EuroNanoForum 2013 .....</i>	<i>70</i>
<i>Presentation Highlights.....</i>	<i>71</i>
Nanomedicine: Technology Platforms and Breakthrough Projects (Workshop 7) .....	71
Market Strategies in the Medical Device Industry (Workshop 8) .....	74
<b>Dissemination Highlights.....</b>	<b>76</b>
<i>Published journal articles, conference proceedings and book sections .....</i>	<i>76</i>
First year (July 2010–June 2011) .....	76
Second year (July 2011–June 2012).....	77
Third year (July 2012–June 2013).....	78
Fourth year (from July 2013).....	80
Accepted/in press.....	82
<i>Conferences and seminars: Invited talks, oral communications and posters .....</i>	<i>83</i>
First year (July2010–June2011).....	83
Second year (July 2011–June 2012).....	85
Third year (July 2012–June 2013).....	87
Fourth year (July 2013–June 2014).....	92
<b>Special Events.....</b>	<b>97</b>
<i>Organized workshops, schools and seminars .....</i>	<i>97</i>
Organized events for stakeholders and public engagement:.....	97
Organized Workshops: .....	97
Industrial presentations, workshops and trade fairs.....	98
<b>Acknowledgements.....</b>	<b>99</b>
<b>Funding.....</b>	<b>99</b>





## Preface

Nanomedicine promises to bring better health care, better health economics and truly personalized medicine. Drug delivery has and will greatly benefit from nanotechnology-driven innovation, thus providing safer and more efficient therapies. Nanotechnology is also driving the development of novel imaging tools and devices for structural and functional imaging. Insufficient sensitivity and specificity of current diagnostic tools are means there is a need for innovative molecular diagnostics and treatment monitoring devices, which should be highly sensitive to allow for early detection of symptoms, sufficiently and reliably informative, low-cost, fast, easy to use, and safe. These are the main challenges to the development of future diagnostic/monitoring systems that nanotechnology promises to tackle. Portable point-of-care diagnostic devices and multi-parametric readouts for therapy monitoring and personalized medicine are among the most promising areas of modern diagnostics where the impact of nanotechnology is already enabling outstanding innovation. Nanotechnology also offers the opportunity to improve existing diagnostic systems such as PET and MRI, to introduce a new generation of imaging systems and to expand the overall scope of the molecular imaging field.

Since the advent of nanomedicine, Europe has established itself as a major driver for the global market, especially in the medical devices industry sector. The European NanoMed Map, recently developed by the European Technology Platform on Nanomedicine through the funded Coordinated Support Action project, NanoMed2020, shows that the nanomedicine community counts at least 1500 European main actors; these include more than 500 industrial players and SMEs active in the field, and 1000 actors conducting high-quality research in universities and research centres across Europe.

Integration of academic research and industrial expertise, as well as integration of expertise among different scientific fields, are now key issues for effective transfer of scientific discoveries into marketable products. Although scientific and technological innovations are the basis of nanomedicine, the greatest barriers

between potential patient benefits and their realization are neither scientific nor technical. Translating scientific and technological excellence into effective therapeutic and diagnostic modalities requires experts from different fields to cross disciplinary boundaries in order to create truly multidisciplinary environments, and to make outcomes available to the whole stakeholder community.

In this context, several EU projects and professional networks are integrating to add value to European nanomedicine: These include the European Technology Platform on Nanomedicine; the Cluster, “Targeted Nano-Pharmaceuticals and Early Diagnostics”; the European Foundation for Clinical Nanomedicine (CLINAM) and its European Summit for Clinical Nanomedicine; as well as large-scale FP7 projects such as NAMDIATREAM, MULTIFUN, SAVEME, NANOFOLS and 3MICRON, among many others.

The European Technology Platform on Nanomedicine (ETPN) has identified several challenges for the realization of an effective open innovation model across Europe. Improving the dialog between different academic disciplines, industries, clinical organizations and regulatory agencies is considered a top priority by ETPN, and this was discussed extensively at the yearly CLINAM summit, which aims at presenting and reflecting on the latest nanoscience-related advances in medicine by supporting clinically focused research and interaction across the whole community of nanomedicine stakeholders.

To facilitate such interaction, it is essential to organize multi-disciplinary events where nanomedicine stakeholders can gather with the aim of sharing each other's potentials and needs. Together with ETPN, CLINAM, and the existing professional clusters and networks in nanomedicine, large-scale European projects can act as catalysts for the creation of multidisciplinary exchange grounds. The sharing of knowledge and ideas that have developed in the course of one project, with other researchers working in the field and with the extended stakeholder community, can bring us closer to achieving real health and societal benefits.





This was the goal of the dissemination events organized by the large-scale collaborative EU-funded FP7 project, NAMDIATREAM (NAnotechnological toolkits for Multi-modal cancer DIAGnostics and TREATment Monitoring, NAMDIATREAM). The aim of the project was development of innovative imaging tools for multi-platform diagnostic approaches through four Technology Platforms (TPs): TP1 focused on monodispersed CdSe/ZnS quantum dots (“lab-on-a-bead”); TP2 was based on plasmon-optical detection of the relaxation dynamics of magnetic nanorods (“lab-on-a-wire”); TP3

tries (Ireland, Spain, Austria, Germany, France, Italy, Belgium, UK) and 1 associated country (Switzerland).

The international and multidisciplinary dimensions of NAMDIATREAM went beyond the composition of its partners, as it gathered other projects and expertise by arranging outreach events in the fields of nanotechnology-enabled molecular imaging, therapeutics, and market strategies for nanomedicine. Some of the most influential experts and projects in the field were brought together during the Nanotechnology workshop at the World Molecular Imaging Conference, 2012, in Dublin,

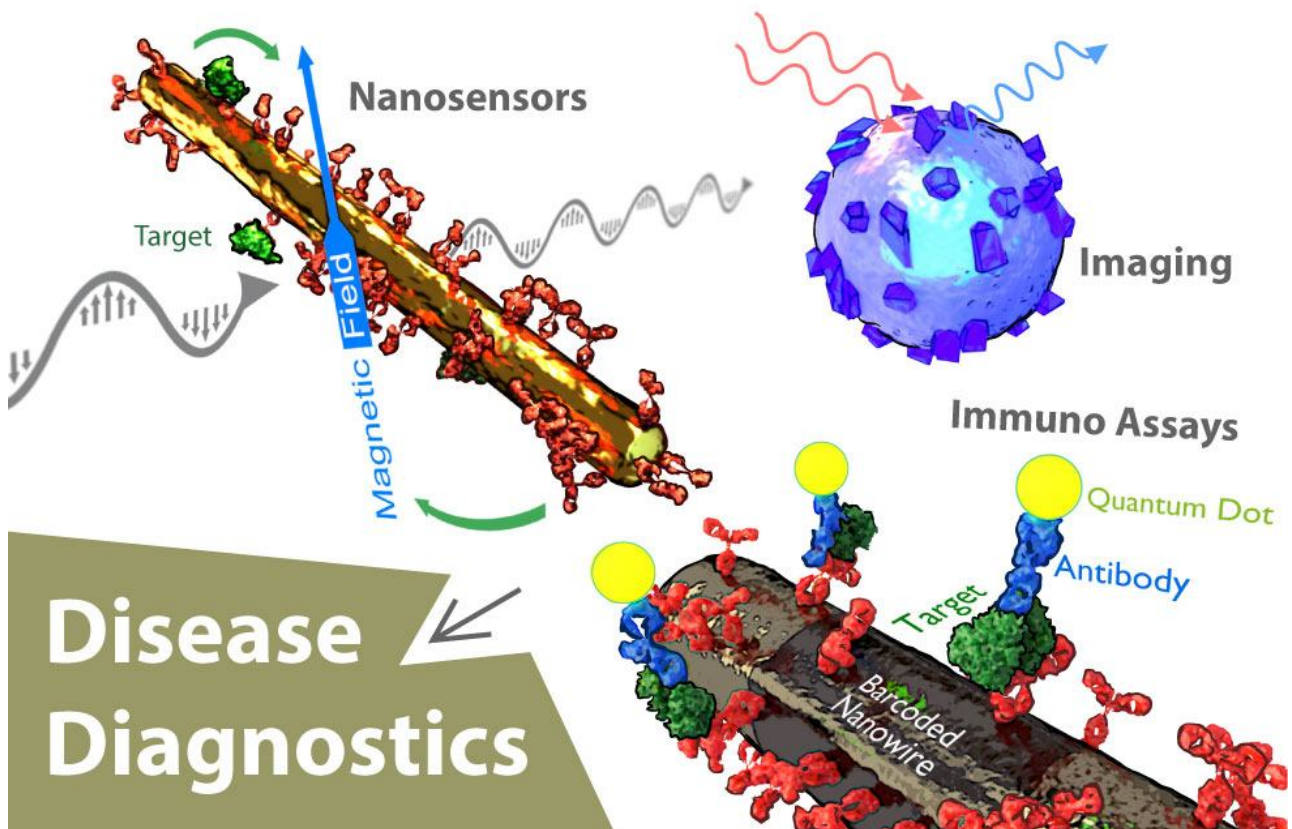

concerned second-harmonic generating nanoparticles (“lab-on-a-bead”); and TP4 combined magnetically bar-coded nanowires (“lab-on-a-wire”) with advanced microfluidics (“lab-on-a-chip”).

NAMDIATREAM was coordinated by Prof. Yuri Volkov of Trinity College Dublin and comprised 22 partners, including 7 high-tech SMEs and 2 multinational corporations, with complementary skills and facilities provided by research institutions in 8 European Coun-

tries and at the Winter School on “Bioimaging, sensing and therapeutic applications of nanomaterials” at Villars-sur-Ollon in march 2013. NAMDIATREAM also brought results to the floor of the EuroNanoForum 2013 conference (its own as well as those of other European projects); this was a unique opportunity to communicate the huge potential of nanotechnology, as an enabling technology for medical applications, to a large panel of research, industry and public authority representatives.



Through the success of these events, NAMDIATREAM has catalyzed the creation of a common ground for discussion of scientific and industrial innovation strategies amongst those with different experiences and interests.

A major result of such outreach activities was the highly productive interaction with the MULTIFUN FP7 project, where Trinity College Dublin is also involved as partner and work package leader. MULTIFUN (Multi-functional Nanotechnology for selective detection and treatment of cancer) is a large-scale EU-funded collaborative project whose aim is to develop multifunctional magnetic nanoparticles (MNPs) for diagnosis and treatment for breast and pancreatic cancer. The project's main objectives are (i) synthesis of MNPs as contrast agents for MRI, (ii) development of specific bi-

omarkers for targeting breast and pancreatic cancer stem cells (early diagnosis) and (iii) development of new technologies for the detection and quantification of nanoparticles in tissue, blood and urine.

Fruitful interactions have also been established with other large-scale FP7 projects, major European organizations and industrial partners, as described in the present document. This booklet aims to provide an overview of the multidisciplinary activities initiated by the Nanomedicine Research Group of Trinity College Dublin (Ireland) and its collaborating partners through participation in the NAMDIATREAM and MULTIFUN projects (FP7 NMP LSP projects funded over the period 2009–2015) and also as part of its broader pan-European engagement.

# Workshop at the World Molecular Imaging Congress 2012

Nanotechnology in Diagnostics, Monitoring and Treatment of Cancer:  
Advances in Molecular Imaging



IAEA  
International Atomic Energy Agency

Images courtesy of  
the World Molecular  
Imaging Society  
WMIS.org





## Overview of Workshop

The NAMDIATREM Workshop, titled, **Nanotechnology in Diagnostics, Monitoring and Treatment of Cancer Advanced in Molecular Imaging**, was held within the fifth annual meeting of the World Molecular Imaging Congress (WMIC), the premier event in molecular imaging worldwide. WMIC 2012 attracted more than 1750 attendees to the Dublin Convention Centre from September 5<sup>th</sup>–8<sup>th</sup> with over 60 companies exhibiting the latest instruments and techniques for clinical and pre-clinical imaging.

The goal of the NAMDIATREAM workshop was to bring together and show some of the most important scientific outcomes of EU projects aimed at developing innovative nanotechnology-based imaging probes and drug delivery carriers for diagnostic and theranostic purposes.

Overall, WMIC 2012 was attended by scientists and stakeholders, covering an impressive worldwide distribution with 41% of people coming from Europe, 40% from North America, 16% from Asia and the remaining 3% from other regions. At the event, presentations were delivered by scientists from academic, clinical and research institutions, with industrial leadership in the field being represented by over 60 exhibiting companies, presenting the latest instruments for clinical and pre-clinical imaging.

More than 110 students and researchers attended the workshop, where 46 International and 4 Irish scientists from diverse areas of the Molecular Imaging field had a chance to present their latest results and share their research experience.

### Presentation Highlights

Over 110 scientists convened at the NAMDIATREAM Workshop to present their approaches to diagnosis, monitoring and treatment of some of the major diseases of the 21<sup>st</sup> century, in particular cancer. Over 20 oral presentations were organised into four sessions, followed by a poster session.

The first session was titled, **Advances in imaging and diagnosis by nanotechnological tools**, and it showcased results and technologies from the NAMDIATREAM project.

Prof. Yuri Volkov from Trinity College Dublin (Ireland) presented the MagBar technology (TP4) as a diagnostic nanotool based on magnetically barcoded nanowires and quantum dots. MagBar technology promises to deliver a system for detection of very low quantities of cancer markers in biological fluids (increased sensitivity). It will also allow for simultaneous use of multiple markers (increased information), identification of rare circulating cancer cells and micrometastases (lower diagnostic thresholds and better prognostic value), and devices for personalized point-of-care use (opportunities for routine diagnostics and dynamic treatment monitoring). Prof. Luigi Bonacina from the University of Geneva (Switzerland) presented TP3, second-harmonic generating nanoparticles, which aim to provide an inherently nonlinear, photostable, infrared-excitable microscopy probe with multimodal detection capabilities. Prof. Joerg Schotter from the Austrian Institute of Technology (Austria) presented the Plasmag system as a homogeneous immunological detection tool; the system is based on optical detection of the magnetic relaxation times of hybrid magnetic-core, gold-shell nanorods. Prof. Igor Nabiev from Trinity College Dublin (Ireland) presented results relating to applications of fluorescent semiconductor quantum dots for ultrasensitive marker detection and cancer diagnostics. All four presentations also provided an overview of such applications in the “real world” of clinical diagnostics.

NAMDIATREAM industrial partners also presented their advances and their role in the project. Dr. Daniel Ciepiewski outlined Nikon’s (France) approach to nanotechnology for advanced imaging. Dr. Frans Nauwelaers highlighted BD Bioscience’s (Belgium) efforts to evolve flow cytometry from cellular to sub-cellular analysis through nanotechnology-based imaging. Finally, Dr. Patrick Hole discussed the use of NanoSight NTA (UK) for the measurement of exosomes and other nanosized biological particles.

The second session concerned **Advances in imaging and theranostics using nanotechnological tools** and presentations were from the MULTIFUN project. MULTIFUN (Multifunctional Nanotechnology for selective detection and treatment of cancer) is a large-scale EU-

funded collaborative project whose aim is to develop multifunctional magnetic nanoparticles (MNPs) for diagnosis and treatment for breast and pancreatic cancer. The project objectives related to diagnosis were introduced by Prof. Rodolfo Miranda from IMDEA Nanoscience (Spain) as: (i) synthesis of MNPs as contrast agents for MRI, (ii) development of specific biomarkers for targeting breast and pancreatic cancer stem cells (early diagnosis), and (iii) development of new technologies for the detection and quantification of nanoparticles in tissue, blood and urine.

MULTIFUN strategies for the synthesis and dispersion of magnetic nanocrystals for advanced MRI imaging and hyperthermia were presented by Prof. Maria del Puerto Morales from CSIC (Spain). She also pointed out the main technical challenges to the development and characterization of these nanoparticles.

MULTIFUN strategies for multifunctionalization of magnetic nanoparticles for theranostic applications, specifically for breast and pancreatic cancers, were described by Dr. Aitziber L. Cortajarena from IMDEA. Dr. René Botnar from King's College London (UK) reported results concerning the *in vitro* behaviour of hydrophilic magnetic nanoparticles that are to be used as MRI contrast agents. Then, Dr. Ingrid Hilger from the University of Jena (Germany) offered an overview on the clinical use of magnetic nanoparticles and the challenges that face the development of such strategies. The last presentation of this session was by Dr. Stephanie Teughels from Pepric (Belgium) and it described new devices for quantitative monitoring of the biodistribution and kinetics of magnetic nanoparticles and labeled cells and tissues.

The third-session presentations were delivered by members of the **Targeted Nano-Pharmaceuticals and Early Diagnostics** cluster, which brings together about 25 research projects funded by the EU Sixth and Seventh Framework Programmes for Research (FP6 and FP7), under the priorities, NMP and HEALTH. Dr. Adriele Prina-Mello from Trinity College Dublin (Ireland) introduced the cluster, whose aim is to develop state-of-the-art nanotechnological methods for diagnosing, monitoring and treating a wide variety of diseases, including cancer. In particular, this session hosted presentations from the SAVEME, NANOFOL and 3MICRON projects.

Dr. Louis Shenkman (Israel) showed results from the SAVEME project, which is developing a novel modular nanosystem platform, integrating advanced functionalized nano-core particles and active agents. NANOFOL was presented by Dr. Artur Cavaco-Paulo (Portugal) who outlined the development of folate-based nanobio-devices for integrated diagnosis/therapy targeting chronic inflammatory diseases. Finally, 3MICRON aims at developing a three-modality contrast-imaging system using multi-functionalized magnetic polymeric microbubbles, as described in the presentation of Prof. Hans Herbert (Sweden).

The last session of the Workshop centred on **Imaging cell and tissue interaction with nanomaterials**. Advanced experimental model systems for imaging cancer cells were the subject of the presentation given by Prof. Frauke Alves, Her team at the Max Plank Institute (Germany) has optimized *in vivo* models (mouse) for lung, pancreas and breast cancer to evaluate the sensitivity and specificity of the photoluminescent quantum dots developed in the NAMDIATREAM project; which were compared to standard controls and existing detection labels. New developments in imaging of *in vitro* models were also on show here, in the presentations of Dr. Dania Movia and Dr. Adriele Prina-Mello from Trinity College Dublin. Dr. Movia proposed 3D cell systems as novel *in vitro* models for studying nanomaterial interactions with tissues. The results of imaging and cytotoxicity testing of single wall carbon nanotubes (SWNTs) in such 3D, tissue-like models were presented. Dr. Prina-Mello then described the use of a high-content screening system for the analysis of cellular responses to nanomaterials, emphasizing its effectiveness as an imaging and decision-making tool.

The application of Raman techniques to clinical imaging was outlined by Dr. Furio Gramatica from the Don Gnocchi Foundation (Italy). In particular, Dr. Gramatica proposed a self-assembled SERS platform for biomarker detection, which can be implemented into a "lab-on-a-chip" system, ideal for clinical applications such as hospital lab tests and point-of-care tests.

The implications of nanotoxicology in nanomedicine were addressed by Dr. Marcello Cacace from CNR (Italy). Dr. Cacace pointed out that both nanomedicine and nanotoxicology examine new and sometimes un-



foreseen effects emerging from bionano interactions; one seeks to exploit these effects for the benefit of our health, whereas the other aims to find, understand and minimize those that are undesirable.

## Outcomes

The World Molecular Imaging Congress attracted 1200 abstracts; hosted 250 oral presentations and four poster sessions, and provided 14 educational sessions, 7 spotlight sessions and 5 industry workshops. Within this world-class, international framework, the NAMDI-ATREAM Workshop effectively engaged leading molecular imaging experts and industrial players to share their views and results on current and future applications of nanotechnology for disease diagnosis and treatment, and to highlight the pathways to implementation of nanotechnologies in clinical molecular-imaging practice.

The cutting-edge presentations were delivered by scientists, clinicians and industrial leaders from across Europe.

Trinity College Dublin under an SFI Conference and Workshop grant (awarded to Prof. Volkov and collaborator, Dr Prina-Mello) provided nearly 150 travel grant awards to attendees receiving the best scores. In addition, this grant provided for 3 young investigator awards and 10 poster awards to recognize innovative research by young investigators, including junior faculty. Indeed, throughout the workshop, young scientists were provided the opportunity to highlight their achievements and share their experiences with established researchers in an informal networking atmosphere.

## Program of the Workshop at the World Molecular Imaging Congress 2012

### **(I) Advances in imaging and diagnostics using nanotechnological tools**

Nanotechnology in diagnostic monitoring and treatment of cancer: Advances in molecular imaging  
Harmonic nanoparticles for biolabelling  
Plasmonic magnetic detection for advanced clinical diagnostics  
Quantum dots as fluorescent probes for advanced imaging  
Nanotechnology in advanced imaging  
Evolving flow cytometry from cellular to sub-cellular analysis  
The use of NanoSight NTA to measure exosomes and other nanosized biological particles

### **(II) Advances in imaging and theranostics using nanotechnological tools**

MULTIFUN: Project highlights  
Magnetic nanoparticles for advanced MRI imaging and hyperthermia  
Functionalization of magnetic nanoparticles for theranostics  
Nanoparticles and advanced MRI detection and imaging  
Clinical use of magnetic nanoparticles  
New devices based on advanced imaging

### **(III) Cluster: Targeted nanopharmaceuticals and diagnostics**

Overview of targeted nanopharmaceuticals and diagnostics cluster activity  
Folate-based nanobiodevices for integrated diagnosis/therapy targeting chronic inflammatory diseases  
SaveMe: A modular active nano-platform for advanced cancer management — Core nanosystems, tumour targeting and penetration, molecular imaging and degradome based therapy  
3 Micron: Multimodality microballoons

### **(IV) Imaging cell and tissue interaction with nanomaterials**

Advanced models for imaging cancer  
Nanotoxicology implications in Nanomedicine: unanswered questions and future directions  
Imaging cell and tissue interaction with nanomaterials: From 2D to 3D models  
Raman spectroscopy in clinical diagnostics  
High content screening of cellular response to nanomaterials interaction as imaging and decision-making tool

# Presentation Abstracts

## (I) Advances in imaging and diagnostics using nanotechnological tools

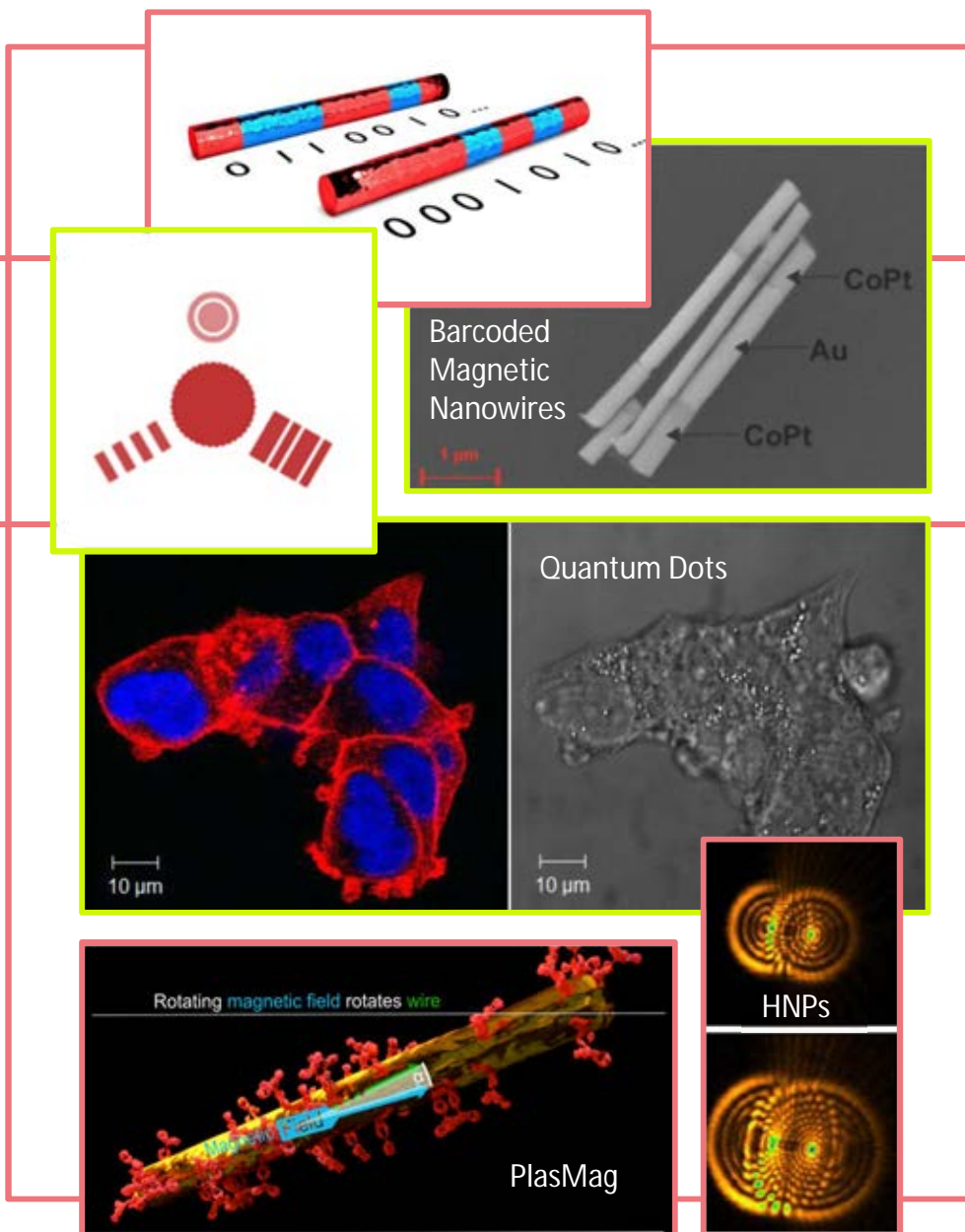





## Nanotechnology in diagnostic monitoring and treatment of cancer: Advances in molecular imaging

Yuri Volkov; Department of Clinical Medicine, School of Medicine, Trinity College Dublin, Ireland.

The recent advances in nanotechnology have opened up new opportunities in the diagnosis, monitoring and treatment of cancer. In particular, the opportunity to develop cutting-edge nanotechnology-based toolkits for multi-modal detection of biomarkers of the most common cancer types and cancer metastases is permitting the identification of cells indicative of early disease onset. This is critical for cancer, considering over 3.2 M new cases and 1.7 M cancer-related deaths are registered in Europe every year, largely because diagnostic methods have an insufficient level of sensitivity, limiting the potential for early disease identification.

In fact, it is foreseen that advances in molecular imaging for *in vivo* and *in vitro* research will be focused on increasing the specificity, sensitivity and reliability of clinical, laboratory and point-of-care devices. The NAMDIATREAM project is built on the innovative concepts of super-sensitive and highly specific “lab-on-a-bead”, “lab-on-a-chip” and “lab-on-a-wire” nano-devices, which utilize photoluminescent, plasmonic, magnetic and non-linear optical properties of certain nanomaterials. This offers ground-breaking advantages

over present technologies in terms of stability, sensitivity, time of analysis, probe multiplexing, assay miniaturization, reproducibility, cost and safety.

Through the implementation of these innovations, the project will deliver the following: (1) Photoluminescent nanoparticle-based reagents and diagnostic chips for high throughput, early diagnosis of cancer and treatment efficiency assessment; (2) Nanoparticles enabling plasmon-optical and nonlinear optical monitoring of molecular receptors within body fluids or on the surface of cancer cells; (3) Multiparametric screening of cancer biomarkers in diagnostic material using segmented magnetic nanowires; (4) Validation of nanotools for early diagnosis and highly improved specificity in cancer research and (5) OECD-compliant nanomaterials with improved stability, signal strength and biocompatibility.

Direct lead users of the results will be the diagnostic and medical imaging device companies involved in the consortium, along with clinical and academic partners.

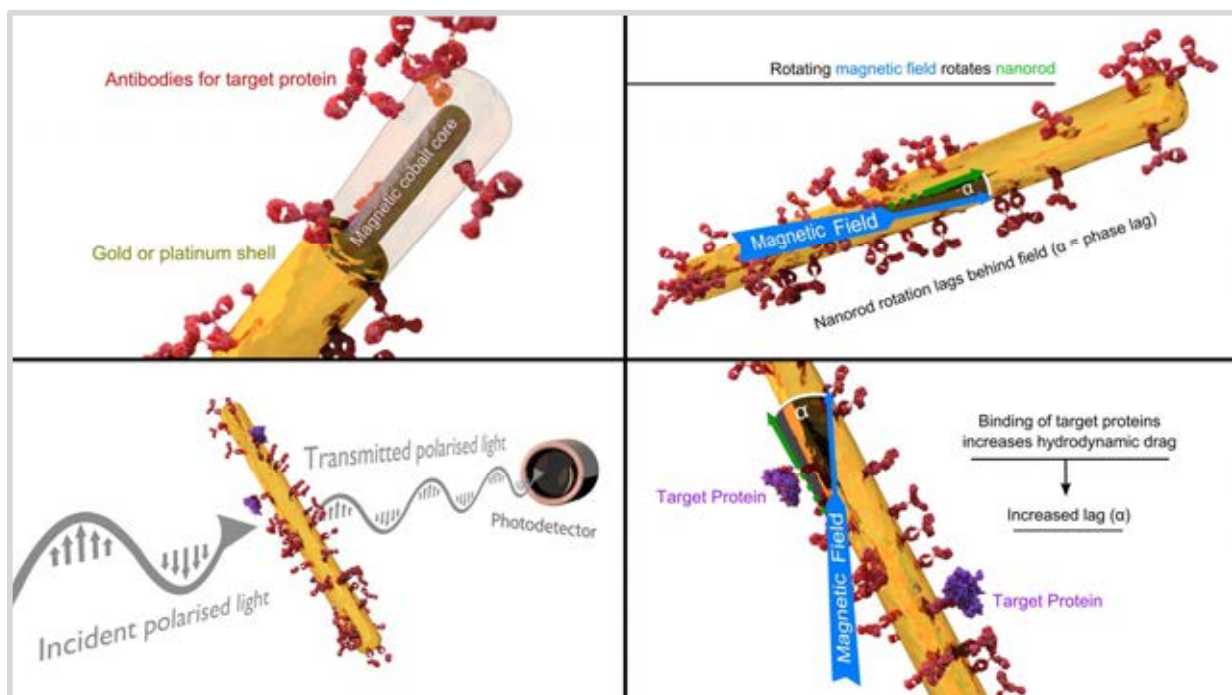



**Yuri Volkov, (PhD, MD, MA, FTCD)**

Yuri Volkov received his MD from the Moscow Medical University and subsequently a PhD in biomedical sciences from the Institute of Immunology, Moscow. He is a Professor at the Department of Clinical Medicine and former Director of Research at the School of Medicine, Trinity College Dublin (TCD). Prof. Volkov coordinates a large-scale EU FP-7 project, NAMDIATREAM, for early diagnostics and monitoring of malignant diseases, with 22 European academic, research, clinical and industrial partners. He is the lead TCD partner for the EU FP-7 project, MULTIFUN, and Principal Investigator on a number of other grants. Prof. Volkov is the author of over 100 scientific publications, including articles and book chapters, and he is an inventor on several patents.



## Harmonic nanoparticles for biolabelling

Luigi Bonacina, GAP-Biophotonics, University of Geneva, Geneva, Switzerland.

In the quest for the next generation of imaging biomarkers, successful probes have to prove to be non-toxic, bright, stable against long term excitation, and able to generate a sharp contrast against background fluorescence. In all these respects, Harmonic Nanoparticles (HNPs) are receiving an increasing attention as they also open a series of alternative detection possibilities simply not accessible with the present generation of fluorescent dyes and quantum dots. HNPs are a family of inorganic nanometric crystals (size < 100 nm) of different materials (KNbO<sub>3</sub>, BiFeO<sub>3</sub>, LiNbO<sub>3</sub>, KTP, etc.)

sharing the characteristic of non-centrosymmetric crystal structure. This property determines their large non-linear optical efficiency, and, in fact, in the last years they have been mostly investigated as localized sources for second harmonic generation. After introducing this approach and comparing it with respect to other nanoparticles-based optical labelling strategies (quantum dots, up-conversion NPs), I will highlight some recent applications in the field of (multi-photon) imaging and optical detection of HNPs labelled biological samples.

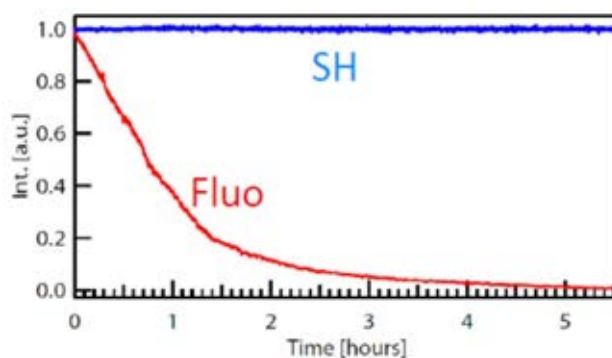
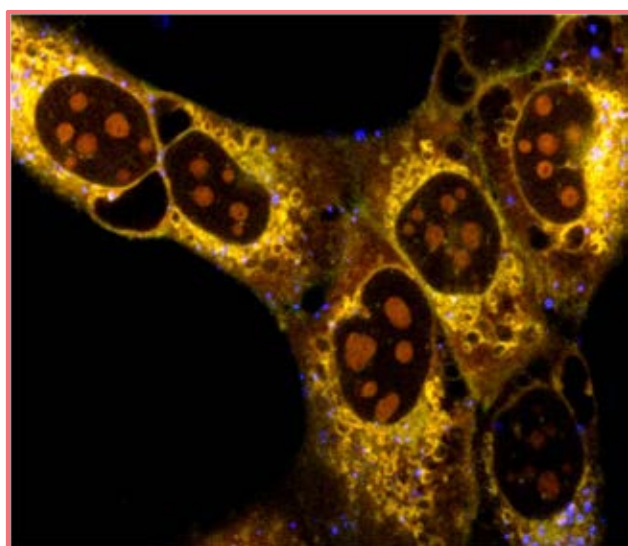

### Luigi Bonacina, PhD

Luigi Bonacina obtained a Master degree in Optics from the University of Milan in 1999. Successively, he moved to the Ecole Polytechnique Fédérale de Lausanne, where he completed a PhD in 2004 in the Chemistry Department with a project on ultrafast spectroscopy. In 2012, he was appointed a permanent research position at the Physics Department of the University of Geneva, in the Biophotonics group. His main research interests include the development of nonlinear and phase-coherent optical techniques for imaging and spectroscopy of biological systems. Recently, he has focused his activities on multi-photon nanotechnology-based approaches for cancer detection and treatment.



## Plasmonic magnetic detection for advanced clinical diagnostics

Joerg Schotter<sup>1</sup>, Stefan Schrittwieser<sup>1</sup>, Frank Ludwig<sup>2</sup>, Jan Dieckhoff<sup>2</sup>, Katerina Soulantica<sup>3</sup>, Guillaume Viau<sup>3</sup>, Sergio Mozo Lentijo<sup>3</sup>, Colin Self<sup>4</sup>, Patrick Hole<sup>5</sup>, Joanna Sullivan<sup>5</sup>, Annegret Guenther<sup>6</sup>, Andreas Tschoepe<sup>6</sup>; (1) Health and Environment Department, Austrian Institute of Technology, Austria; (2), Institute of Electrical Measurement and Fundamental Electrical Engineering, Technical University Braunschweig, Germany; (3) INSA, UPS, LPCNO, and CNRS, Université de Toulouse, LPCNO, France; (4) Selective Antibodies Ltd., United Kingdom; (5) NanoSight Ltd., United Kingdom; (6) Universität des Saarlandes, Experimentalphysik, Germany.

We introduce a new biosensor concept (denoted as 'PlasMag'), which is based on highly sensitive plasmon-optical detection of the rotational dynamics of anisotropic magnetic nanoparticles immersed in the sample solution. On the specific binding of analyte molecules to the antibody-functionalized nanoparticle surfaces, their hydrodynamic volumes increase, which translates into a change in their rotational dynamics. A suitable nanoparticle type consists of an elongated core-shell structure with magnetic core and noble metal shell. Thereby, the magnetic core enables control of the nanoparticle alignment by external magnetic fields, while the anisotropic plasmon resonance excitation within the noble metal shell in linearly polarized light allows optical detection of the nanoparticle's rotational dynamics. Compared to existing nanoparticle-based homogeneous immunodiagnostic methods, our approach promises to combine ease of use, minimum sample preparation and a simple setup with high analyte sensitivity.

We present model calculations of the optical, magnetic and hydrodynamic properties of both the required nanoparticles and measurement conditions. According to these, core-shell nanorods with a cobalt core surrounded by a gold shell agitated by a rotating magnetic field are best suited for our biosensing principle.

While we currently strive to synthesize such nanorods, we still have to solve stability issues of respective nanorod dispersions. Thus, as an intermediate solution we demonstrate the 'PlasMag' detection principle using aqueous dispersions of nickel nanorods fabricated by electrodeposition into nano-porous alumina templates. Specifically, we show that the phase lag of the long axis of nickel nanorods (magnetic core parameters: medium length 182 nm, medium diameter 26 nm) with respect to externally applied rotating magnetic fields significantly increases on the adhesion of bovine serum albumin (BSA) protein to their surfaces. By fitting our measurement results, we obtain a large increase of the hydrodynamic shell thickness of the nanorods by 22 nm, which is related to both the size of the adsorbed protein molecules as well as changes in the stagnant surface layer of immobile fluid. To validate these results, we independently determine the amount of bound protein molecules by analysis of the electrophoretic mobility of the nanorods, which gives a protein surface density of 5.8 femtomol/mm<sup>2</sup>.

Our results successfully confirm the theoretical model calculations on the rotational behaviour of magnetic nanorod dispersions, thus serving as a first proof of the 'PlasMag' concept.

### Joerg Schotter, PhD

Joerg Schotter is a staff scientist at the Molecular Diagnostics business unit of the Austrian Institute of Technology (AIT). His primary scientific interest is the application of magnetic techniques to molecular diagnostics, which includes both heterogeneous magnetoresistance-based biosensors and lab-on-a-chip systems as well as homogeneous nanoparticle-based molecular detection methods.

Joerg Schotter was born in Friedrichshafen (Germany) in 1975. He received his Master Degree in physics from the University of Massachusetts (Amherst, USA) in 2000, where he studied the fabrication of ultra-dense magnetic nanowire arrays by electrodeposition into nano-porous diblock copolymer templates. He then moved to the University of Bielefeld (Germany) to prepare his PhD thesis on the development of magnetoresistive biosensors, which he finished in 2004. Since 2005, he is employed by the AIT as staff scientist, where he continues his research on magnetic biosensor systems. He has authored more than 30 original research papers.



## Quantum dots as fluorescent probes for advanced imaging

Alena Sukhanova<sup>1</sup>, Hilal Hafian<sup>2</sup>, Jean-Marc Millot<sup>2</sup>, Michel Pluot<sup>2</sup>, Jacques H.M. Cohen<sup>2</sup>, Patrick Chames<sup>3</sup>, Daniel Baty<sup>3</sup>, and Igor Nabiev<sup>1,4</sup>; (1) School of Medicine, Trinity College Dublin, Ireland; (2) Laboratoire de Recherche en Nanosciences, Université de Reims Champagne-Ardenne, Reims, France; (3) Inserm U1068 and CNRS UMR7258 CRCM, Institut Paoli-Calmettes, Aix-Marseille Université, Marseille, France; (4) Laboratory of Nano-Bioengineering, National Research Nuclear University ("Moscow Engineering Physics Institute"), Moscow, Russian Federation.

High-quality imaging for immunofluorescence diagnosis requires a high sensitivity of labeling and discrimination of the tissue autofluorescence. Multiphoton microscopy with excitation in the near-infrared spectral region has now become the primary fluorescence imaging technique for thick biological specimens. The main problem for fulfilling the important multiphoton imaging task is the inherently low TPACS of organic fluorophores. These facts determine an inherently low spectral sensitivity of two-photon bioimaging with organic dyes whereas the semiconductor quantum dots (QD) two-photon absorption cross-sections (TPACS) are orders of magnitude bigger, making them the best fluorescent label to be used for multiphoton imaging.

With a molecular weight of only 13 kDa, single-domain antibodies (sdAbs) are the smallest Ab fragments capable of binding their antigens with affinities comparable to conventional Abs. A sdAb is only 1/12 as large in volume as a conventional IgG molecule, and their size allows them to bind epitopes inaccessible to conventional IgGs. In addition to their small size, sdAbs are characterized by a low tendency to aggregate, diffuse much better in tissues than full-size IgGs, and their

size allow them to label thinner and more distal segments. These advantages make sdAbs the best capture molecules to prepare QD-based fluorescent nanoprobes for biodetection and diagnostics.

We have recently developed a protocol for highly oriented conjugation of sdAbs with QDs, with all sdAb antigen-recognizing sites facing outwards, which considerably increases the nanoprobe sensitivity. These conjugates displayed excellent specificity and quantitative discrimination of tumor and normal cells in flow cytometry. Additionally, the quality of immunohistochemical labeling of biopsy samples with these conjugates was found to be comparable to the quality obtained with gold standard protocols of anatomopathology practice. Finally, we have analyzed the two-photon optical properties of highly oriented sdAb-QD conjugates of QDs with sdAbs, applied them to imaging of normal colon epithelium and pathological human colon carcinoma and determined the optimal conditions for two-photon tissue imaging with this nanoprobe and achieved the highest ratio of the fluorescence signal from sdAb-QD to the tissue autofluorescence ensuring clear discrimination of tumor areas from normal tissue.

### Prof. Igor Nabiev, PhD, DSci

Igor Nabiev received his PhD in Physics and Mathematics in 1983 from Lomonosov Moscow State University and his DSc degree in Chemistry from the Shemyakin Institute of Bioorganic Chemistry of the Russian Academy of Sciences. After professorships in the USA and France, he was nominated, in 1994, as full Professor of Biophysics in the University of Reims Champagne-Ardenne, France. In 2008–2009 Prof. Nabiev was a recipient of the Walton Award from the Science Foundation of Ireland. Since 2010 he has been Director of Technological Platform Semiconductor Nanocrystals of the "Large" European Project NAMDIATREAM.

At the end of 2011, Prof. Nabiev received a MEGA-grant in the framework of the Program of Attraction of the World Leading Scientists to Russian Institutions of Higher Education and founded the Laboratory of Nano-Bioengineering in the National Research Nuclear University "Moscow Engineering Physics Institute.



## Nanotechnology in advanced imaging

Daniel Ciepielewski; NIKON AG Instruments, Paris, France.

Light microscopy using fluorescent proteins has greatly advanced our understanding of many functional biological systems, however the precision at which cellular structures can be visualized has been limited by the spatial resolution imposed by the diffraction limit of light. Several imaging methods are known to go below the diffraction-limited resolution to smaller values, and novel super-resolution imaging methods using photoactivatable proteins or photoswitchable fluorophores bypass this limitation like STORM.

Super-resolution microscope systems N-SIM (structured illumination microscopy) and N-STORM (Stochastic Optical Reconstruction Microscopy) are presented as methods that challenge the diffraction limit. Super-resolution imaging allows for single molecule detection and localization, providing the ability to follow cellular mechanisms such as the dynamics of transcription factors, as an example.

Nonlinear optical nanocrystals have been recently introduced as a promising alternative to fluorescent probes for multiphoton microscopy collecting their second and third harmonic signal. The multiphoton confocal microscope enables excitation by simultaneous absorption of two photons by a single fluorescent molecule. The intensity of the laser beam converged by the objective lens decreases in inverse proportion to the square of the distance from the focal plane, so that only a fluorescent molecule located within the diffraction-limited volume of the objective lens is excited and emits fluorescence. As a result, two-photon confocal microscopy is suitable for the visualization of single or small aggregates of nanoparticles within cells, as we show here in experiments with nonlinear optical nanocrystals  $\text{KNbO}_3$  nanocrystals coated with or  $\text{KNbO}_3$  SCHRIMP's coated with PEG in stem cell samples.

### Daniel Ciepielewski

Daniel Ciepielewski is the Sales and Marketing Manager at NIKON AG Instruments (Switzerland), a role he has held since 2012. From 2002 to 2012 he worked at NIKON France SAS Instruments (Champigny sur Marne / France), where he covered several functions such as measuring product specialist, application engineer and product specialist in images analysis, specialist consultant speaker in Universities, technical and sales support for export business, European software coordinator for industrial and material sciences, technical and sales manager of the industrial and material sciences sales team, and interdisciplinary business engineer & Nanoscopy I-SPT/STORM product Specialist. Mr. Ciepielewski obtained his Engineer Diploma in Physics and Instrumentation at the Ecole Supérieure d'Ingénieur d'Annecy France in 2002, and his 2 years technical degree DUT in Physical Measures speciality Instrumental Techniques at the University Institute of Technology of Clermont Ferrand-France in 1999. At Nikon AG he presently manages the Instruments Department.



## Evolving flow cytometry from cellular to sub-cellular analysis

Frans Nauwelaers, Line De Kimpe, Tina Van den Broeck; BD Biosciences Belgium, Erembodegem, Belgium.

The basic concepts of cytometry were explained: particle alignment, analysis and sorting. Each of these are essential elements in flow cytometry technology but can be utilized with some flexibility if required. Particle alignment can be controlled via sheath fluid or can be sheathless. Analysis can be achieved with a jet-in-air concept or can be accomplished via a closed cuvette system. Particle sorting can be omitted or included and can be dual beam, quadruple or six-way. Particle purity achieved normally ranges in the 98 to 99.9%.

The evolution of the optical path took about 30 years to come to the integrated design available today. In essence, the original path designed reflected much of the fluorescence microscope setup, but this has been optimized systematically and gradually from collection lens to PMT to filter over the years. Light collection has been changing from open air space to gel-coupled (as in fluorescence microscopy) to including the use of pinholes and optical fibers. Filters have been used as combinations, bandpass, reflection filters and transmission filters. Dyes have evolved from the classic fluorescence stains (fluorescein and TM-rhodamin), to the phycobiliprotein dyes derived from algae, to most recently the synthetic dyes and the multi-layer nanobeads. Actual chemistry technologies can synthesize almost any type of dye based on specifications. Each dye could be associated with a cell characteristic through direct staining (nuclear, pH, protein) or could represent a membrane structure via coupling with a detecting (monoclonal or single domain) antibody.

### Frans Nauwelaers, PhD

Frans Nauwelaers is Director of Scientific Affairs at BD Biosciences Europe. His primary scientific interests are in the fields of: leukaemia, minimal residual disease, stem cells, auto-immune disorders, allergy research, platelet activation and blood bank QC assays.

Frans Nauwelaers was born in Mechelen, Belgium in 1948. He graduated from the University of Leuven where he earned his PhD in Physical Chemistry in 1974. He was research assistant at the laboratory of Thrombosis and Haemostasis and assistant at the Central Clinical Laboratory of the Academic Hospital St Raphael in Leuven until 1980. From 1980, he joined the flow cytometry division (BD FACS Systems) of Becton Dickinson where he held several management positions from 1980 to 1990. From 1990 until 1996 he was General Manager and Vice President of BD Image Cytometry Systems in Leiden, the Netherlands. He was General Manager of NeoPath Europe from 1997 through 1999 and became Director of Scientific Affairs for BD Biosciences in 1999, a position he maintained until the present time.



## The use of NanoSight NTA to measure exosomes and other nanosized biological particles

Patrick Hole; Nanosight, Malvern Instruments Ltd., Minton Park, London Road, Amesbury, UK.

Here we discuss the Nanoparticle Tracking Analysis (NTA) technique that sizes nanoparticles in suspension, based on their Brownian motion on a particle-by-particle basis, and also yields directly a count/concentration measurement. This technique has been extensively applied to the measurement of a wide range of nanomaterials such as exosomes, viruses and VLPs, liposomes, protein aggregates, bacteria as well as a range of engineered nanoparticles for their use as drug delivery nanoparticles.

To date, exosomes research has been constrained by a lack of suitable methods for characterization. Nanoparticle Tracking Analysis (NTA) addresses this need. NTA allows specific exosomes and microvesicles in the

range of 50—1000nm in liquid suspension to be directly and individually visualized and counted in real-time. The technique is easy to use, fast, robust, accurate and cost effective, representing an attractive alternative or complement to existing methods. Operation in fluorescence mode enables characterization and speciation of suitably labelled particles using a range of excitation wavelengths.

Examples of the characterization of several of these will be discussed highlighting the crucial parameters in each case (such as size distribution, concentration, fluorescence) along with sharing steps that have been taken to optimize such measurements.

### Patrick Hole, PhD

Dr Patrick Hole is Head of Development for NanoSight at Malvern Instruments Ltd., a nanoparticle characterization company, providing instruments to both R&D and QA customers that has grown in size and reputation rapidly over the last five years. Patrick has worked with NanoSight for six years and now manages the development of both hardware and software and has brought to production two all-new systems. He is currently responsible for development, production and technical support quality within Malvern Instruments Ltd., managing a team of 14. Previously he completed his PhD at the Optoelectronics Research Centre (ORC) in Southampton in optics and electronics and has a Master's Degree from University of Oxford in Engineering.



## (II) Advances in imaging and theranostics using nanotechnological tools

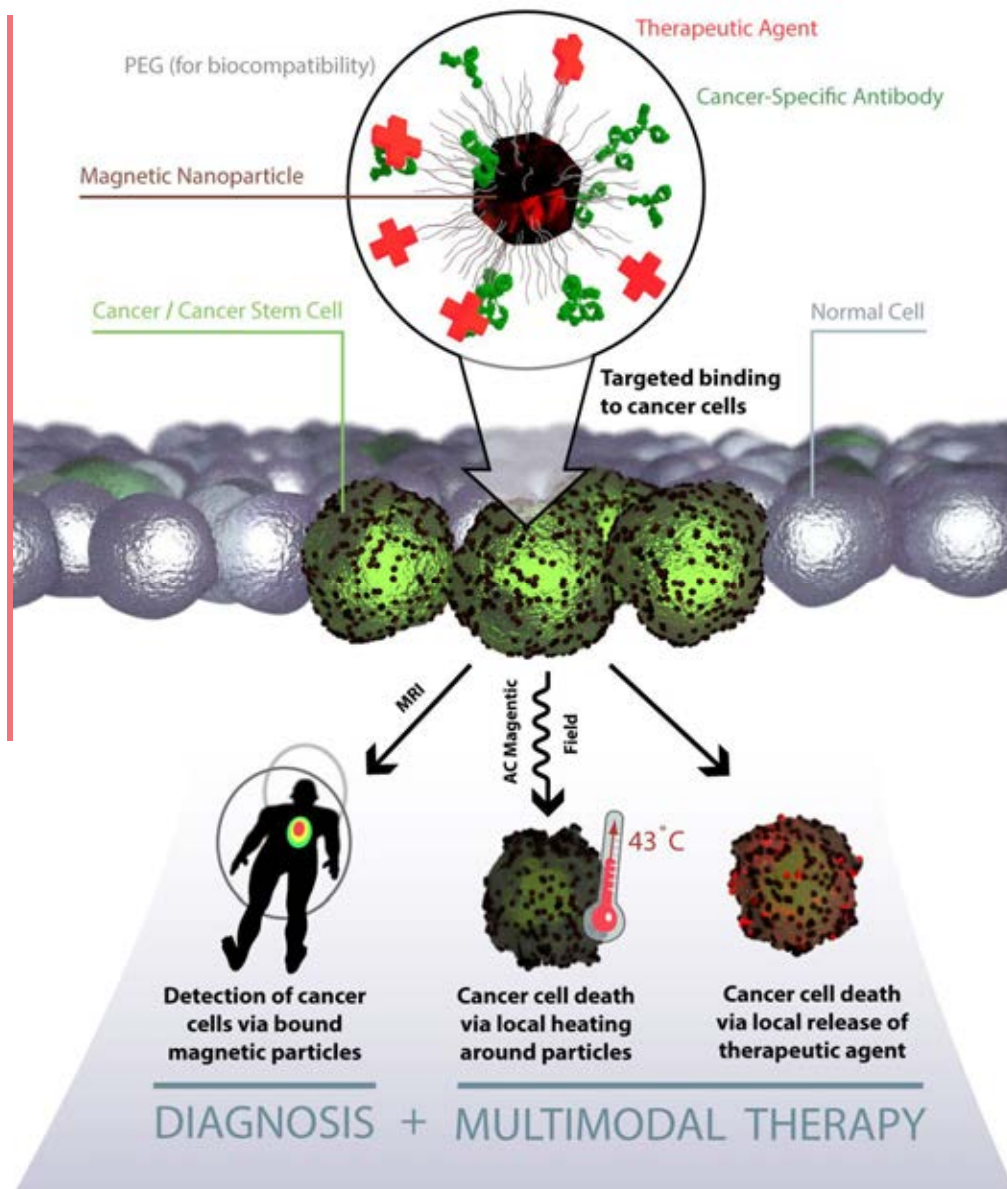



## MULTIFUN: Project highlights

Rodolfo Miranda<sup>1,3</sup>, Aitziber L. Cortajarena<sup>1,2</sup>; (1) IMDEA-Nanociencia, Universidad Autónoma de Madrid, Cantoblanco, 28049 Madrid, Spain; (2) Centro Nacional de Biotecnología (CNB-CSIC) - IMDEA Nanociencia Associated Unit, Universidad Autónoma de Madrid, Cantoblanco, Madrid, Spain; (3) Departamento de Física de la Materia Condensada and Instituto Nicolás Cabrera, Universidad Autónoma de Madrid, Campus Universitario de Cantoblanco, Madrid, Spain.

The aim of the MULTIFUN consortium is to develop and validate a novel and minimally invasive nanotechnology system to improve cancer diagnosis and treatment. MULTIFUN nanotechnology is based on multifunctional magnetic nanoparticles to selectively target and eliminate breast and pancreatic cancer (stem) cells. The improved magnetic features of the MULTIFUN magnetic nanoparticles will lead to potential medical applications such as contrast agents and magnetic heating inductors.

Moreover, magnetic nanoparticles are functionalised with ligands, including targeting peptides and antibodies to increase their affinity towards cancer cells for selective drug delivery and to facilitate diagnosis of tumours by MRI means.

Multifunctional nanoparticles are used simultaneously as functional nanocarriers and heating inductors in order to provide a combined therapeutic modality. The

synergistic effects of drugs, peptides and heat are evaluated to determine the effectiveness of different therapeutic combinations. Thus, MULTIFUN multimodal therapeutic approach is designed to efficiently remove cancer cells from the tumour site.

The toxicity of functionalised magnetic nanoparticles is assessed *in vitro* and *in vivo* to warrant a safe use and shed some light on the risks. The distribution and activity evaluation of functionalised nanoparticles is performed in human breast and pancreatic cancer xenograft models.

Finally, the use of novel magnetic nanoparticles for biomedical applications provides opportunities for development of new instrumentation for detection and quantification of magnetic nanoparticles in blood, urine and tissues and magnetic heating induction.

### Rodolfo Miranda, PhD

Rodolfo Miranda graduated in Physics from the Universidad Autónoma de Madrid (UAM) in 1975. He obtained a PhD in Physics from the UAM in 1980 under the direction of Prof. Juan M. Rojo. Rodolfo Miranda was a Humboldt Fellow in Munich and Berlin (1981-1984) under the supervision of Prof. Dr. Gerhard Ertl, Nobel Prize in Chemistry 2007.

From March 1990, Prof. Miranda is Full Professor of Condensed Matter Physics at the UAM. He was elected Fellow of the American Physical Society in 2007, and, since December 2006, is Director of the Instituto Madrileño de Estudios Avanzados en Nanociencia (IMDEA-Nanociencia), an institution fostering Nanoscience and Nanotechnology in Spain.

His publications (more than 250 by now) have been steadily cited over more than 20 years, totalizing more than 7000 citations. The present h index of Prof. Miranda is 46. He has directed more than 40 projects as Principal Investigator, 30 Ph. D. Thesis and 30 Postdoctoral researchers. He has given more than 100 Invited Talks at international conferences.

Prof. Miranda's interest has covered vastly different topics, from the mechanisms of epitaxial growth to the development of scanning tunnelling microscopy, from basic discoveries in low dimensional magnetism to fundamental studies on molecular self-organization or, more recently, to the growth and properties of graphene and biomedical applications of magnetic nanoparticles. He has developed surface physics and nanoscience in Spain through his students and co-workers. Prof. Miranda is the scientific coordinator of MULTIFUN project.

## Magnetic nanoparticles for advanced MRI imaging and hyperthermia

Maria del Puerto Morales Herrero<sup>1</sup>, Gorka Salas<sup>2</sup>, Marzia Marciello<sup>1</sup>, Lucía Gutiérrez<sup>1</sup>, Sabino Veintemillas-Verdaguer<sup>1</sup>, Carlos J. Serna<sup>1</sup>; (1) Institute of Materials Science of Madrid, ICMM/CSIC, Madrid, Spain; (2) IMDEA Nanociencia, Campus Universitario de Cantoblanco, Madrid, Spain.

Different approaches have been followed to optimize magnetic properties of iron oxide nanoparticles by controlling synthesis parameters. Thus, improvement of crystallinity and uniformity of large magnetite nanoparticles prepared by thermal decomposition of organic precursors can be achieved by controlling nucleation and growth rates by varying constituents and reaction time. Magnetite nanoparticles with diameters between 10 and 20 nm can be obtained with a size distribution lower than 10%, very good magnetic response and consequently high NMR relaxivity parameters and heating efficiency (100 W/g under 70 kHz, 40 mT), which makes them excellent candidates for cancer diagnosis and hyperthermia treatments [1].

On the other hand, magnetite nanoparticles have been synthesized by a simple aqueous route based on the precipitation of an Fe(II) salt in the presence of a mild oxidant, which leads to highly uniform and crystalline magnetic nanoparticles with sizes between 30 and 20

nm, saturation magnetization over 80 emu/g and heating capacities up to 200 W/g under 70 kHz, 40 mT [2]. An important effort has been paid on this preparation route to scale up the synthesis up to 20 grams of particles and reach colloidal stability for long time at high nanoparticle concentrations using biocompatible polymers such as dextran.

Optimization of magnetic properties of these nanoparticles also allows their detection even at low doses by magnetic methods. Detection and quantification of nanoparticles in tissues or organs is possible from the magnetization curves and AC susceptibility curves giving valuable information about nanoparticle pharmacokinetic and biodistribution [3].

1. G. Salas et al., *J. Mater. Chem.* 22 (2012), 21065.
2. M. Marciello et al., Submitted.
3. L. Gutiérrez et al., *J. Phys. D: Appl. Phys.* 44 (2011) 255002.

### Maria del Puerto Morales, PhD

Maria del Puerto Morales is a senior scientist at the Institute of Material Science in Madrid, Spain (CSIC) since 2008. Her research activities are focused on the synthesis and characterization of magnetic nanoparticles for biomedicine.

Maria del Puerto was born in Plasencia (Cáceres, Spain) in 1966. She got her degree in Chemistry by the University of Salamanca in 1989 and her Ph.D. in Material Science from the Madrid Autonomous University in 1993. From 1994 to 1996, she worked as a postdoctoral fellow at the School of Electronic Engineering and Computer Systems of the University of Wales (UK). Her research activities are focused on the area of nanotechnology, in particular in the synthesis and characterization of magnetic nanoparticles for biomedicine. She has authored several book chapters in the field of nanoparticle synthesis and more than 135 articles in interactional scientific journals, has directed 3 doctoral theses and has given numerous conferences and seminars. She is now the principal investigator from the CSIC of the European-funded research project called MULTIFUN and responsible for the Work package on synthesis of multifunctional magnetic iron oxide nanoparticles.



## Functionalization of magnetic nanoparticles for theranostics

Aitziber L. Cortajarena<sup>1,3</sup>, Pierre Couleaud<sup>1</sup>, Alfonso Latorre<sup>1</sup>, Macarena Calero<sup>1,2</sup>, Angeles Villanueva<sup>1,2</sup>, Alvaro Somoza<sup>1,3</sup>; (1) IMDEA-Nanociencia, Universidad Autónoma de Madrid, Cantoblanco, 28049 Madrid, Spain; (2) Departamento de Biología, Universidad Autónoma de Madrid, Madrid, Spain; (3) Centro Nacional de Biotecnología (CNB-CSIC) - IMDEA Nanociencia Associated Unit, Universidad Autónoma de Madrid, Madrid, Spain.

The presented work is part of a European Project called "MULTIFUN" for Multifunctionalization of magnetic particles for selective cancer detection and treatment.

Here, we present the multi-functionalization of dimercaptosuccinic acid (DMSA) coated iron oxide nanoparticles (NPs) with targeting molecules and chemotherapeutic drugs. The DMSA coated iron oxide NPs have been developed by ICMN-CSIC in collaboration with IMDEA-Nanoscience with specific properties for magnetic heating and/or magnetic resonance imaging. We have developed a general approach for the multifunctionalization of magnetic nanoparticles (MNPs) with drugs (Doxorubicin and Gemcitabine) and targeting moieties (Nucant pseudopeptide, antibodies) for controlled and selective release. The functionalization is achieved by the formation of (a) disulfide bonds between MNPs and drugs derivatives synthesized. This approach also allows the quantification of the covalently immobilized molecules. The linkers developed allow the release of drugs without any chemical modification. This process is triggered un-

der highly reducing environment, such as that present inside the cells.

The detailed characterization of functionalised NPs will be presented and discussed. We will also present the *in vitro* studies that show the effective targeting and uptake of DMSA functionalized nanoparticles by breast-cancer cell lines.

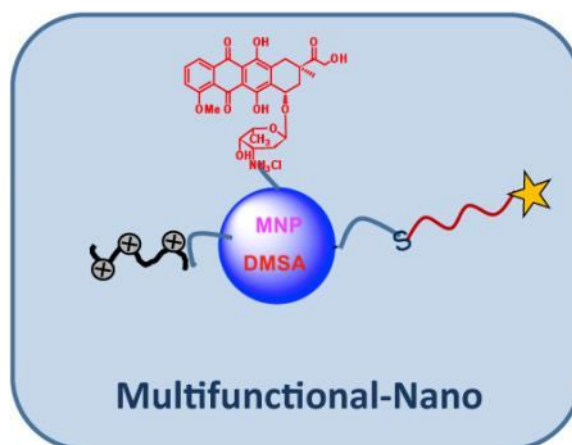

### Aitziber L. Cortajarena, PhD

Dr. Cortajarena earned her PhD in Biochemistry from the Universidad del País Vasco in 2002. Then, she joined the group of Dr. L.Regan at Yale University, USA, as a Postdoctoral Fellow. She worked on protein design, structure and function. In 2006 she was Visiting Scientist at the Weizmann Institute, Israel, with Dr. G.Haran working on single molecule spectroscopy. She continued her work at Yale University, as an Associate Research Scientist with Dr. Regan. She joined IMDEA Nanociencia as Group Leader in January 2010. Her research focuses on protein engineering and generation of biofunctional nanostructures for applications in nano-biotechnology and nano-biomedicine. Dr. Cortajarena is work-package leader (WP2-Multifunctionalization of MNPs) in the MULTIFUN project (FP7-MNP-2010-262943-2).

## Nanoparticles and advanced MRI detection and imaging

Dirk Krüger<sup>1</sup>, Gorka Salas<sup>2</sup>, Macarena Calero<sup>2</sup>, Silvia Lorrio González<sup>1</sup>, María del Puerto Morales<sup>3</sup>, Angeles Villanueva<sup>2</sup>, René M. Botnar<sup>1</sup>; (1) Division of Imaging Sciences & Biomedical Engineering, King's College London, London, United Kingdom; (2) Instituto IMDEA Nanociencia, Madrid, Spain; (3) Instituto de Ciencia de Materiales de Madrid, CSIC, Madrid, Spain.

Limitations of current cancer therapies are nonspecific delivery and poor biodistribution of drugs as well as the lack of an effective modality for tracking delivery and monitoring treatment response. The aim of this project is therefore to develop and validate multifunctional zed magnetic nanoparticles (MF-MNP) to selectively target and monitor delivery and treatment response of MNPs by MRI. MNPs can be used as contrast agents and magnetic heating inductors and can be functionalised with targeting ligands to increase their affinity towards cancer [1]. Here we sought to investigate imaging properties of MNPs and validate these in breast and pancreatic cancer cell lines.

**Subjects and Methods.** We used a water phantom to investigate the longitudinal and transversal relaxation rates of various MNP alone and 24 hours post incubation with human pancreatic carcinoma cells (i.e. PANC-1). We used a 2D multi-gradient-echo sequence (echoes = 5, slice thickness = 3 mm, TE = 1.7 ms, TR = 11 ms, FA = 25°) to measure T2\* and a 2D multi spin-echo sequence to measure T2. T1 was determined by using a sequence that employs two non-selective inversion pulses with inversion times ranging from 20 ms to 2000 ms, followed by eight segmented readouts for eight individual images [2].

All experiments were performed on a clinical 3T Philips Achieva scanner.

**Results.** Three MNPs (ADNH, ASi and OD15) that have been synthesized in the MULTIFUN consortium (Fig. 1) show excellent r1 and r2\* values making them promising contrast agent prototypes for both T1 and T2\* imaging (tab 1). We also showed that MRI can be used to monitor the dose dependent uptake of those nanoparticles (e.g. F1563) by PANC-1 cancer cells as demonstrated by T2\* mapping.

**Conclusions.** We demonstrate that the investigated nanoparticles have good MR imaging properties and can be used to label carcinoma cell lines. The investigated MNPs show promising imaging and labelling properties and will now be investigated in nude tumour bearing mice (BT474, MDA-MB-231, BxPc-3 PANC-1) to evaluate bio-distribution, specificity and suitability for in vivo imaging and therapy.

1. Peng, X.-H., et al., 2008. Int J of Nanomed, 3, pp.311-21.
2. Makowski, M.R., et al., 2011. Nature Med, 17, pp.383-88.

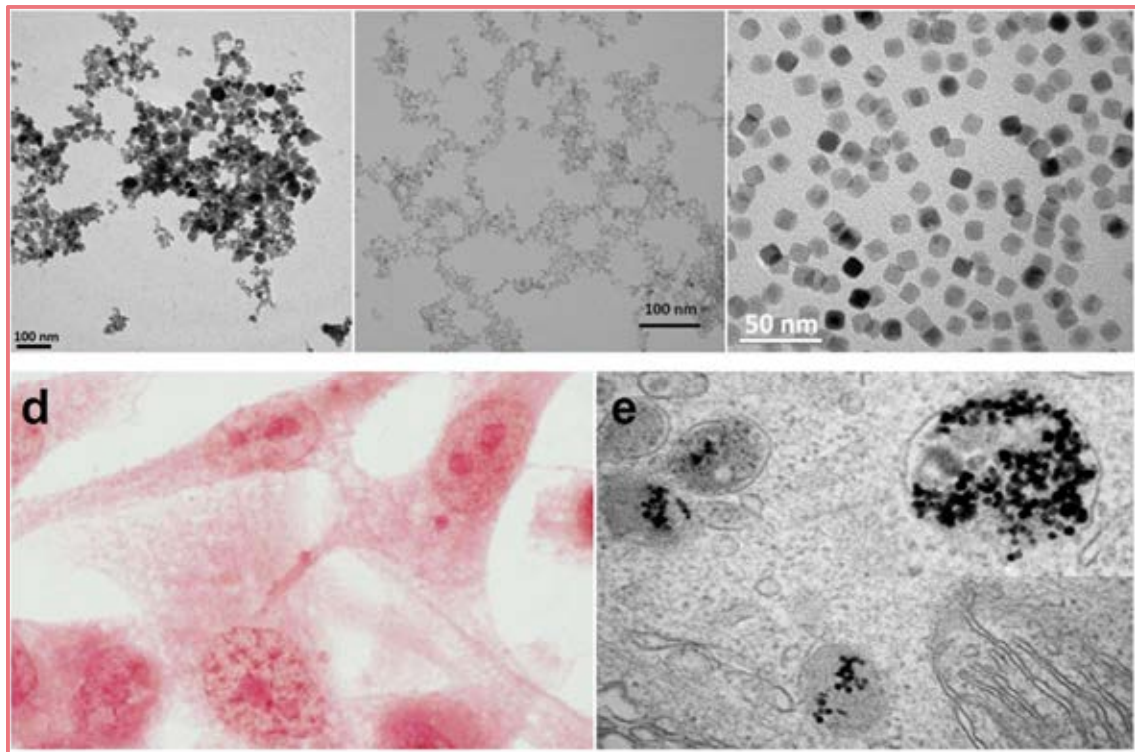

Fig. 1: Transmission electron microscopy (TEM) images of (a) ADNH, (b) ASI and (c) OD15. (d) Light microscopy image of MDA-MB-231 carcinoma cells without any nanoparticles and (e) TEM image after incubation with 15 nm particles (OD15).

### René Botnar, PhD

Dr. Botnar received his PhD from the ETH Zurich. From 1996–97 he was a Research Associate in the Department of Radiology at the University Zurich. In 1997, he joined the Cardiac MR Center at the Beth Israel Deaconess Medical Center and Harvard Medical School where his research was focused on the development and clinical validation of novel MRI sequences and molecular contrast agents for coronary artery lumen and plaque imaging. In 2003, Dr. Botnar became the Scientific Director of the Cardiac MR Center at the Beth Israel Deaconess Medical Center and was appointed to Assistant Professor of Medicine at Harvard Medical School, Boston, USA. In 2005, Dr. Botnar accepted a Professorship of Biomedical Imaging at the Technische Universität München where he set up a cardiac MR program with a special focus on pre-clinical and translational multi-modality imaging. His work was funded by the German Ministry of Research and Education, by the German Excellence Program, and by industry. At the end of 2007, he joined the Imaging Sciences Division at King's College London where he is currently Chair of Cardiovascular Imaging. Dr. Botnar is a Fellow of the International Society of Magnetic Resonance Imaging in Medicine and was a board member of Society for Cardiovascular Magnetic Resonance from 2008-2011. He is on the scientific advisory board of the High Risk Plaque initiative and is also on the editorial board of the European Heart Journal: Cardiovascular Imaging. He has authored more than 175 peer-reviewed original papers, 25 review articles and 20 book chapters in the field of CMR. He also holds 5 patents and is an editor of a CMR textbook on Cardiovascular Magnetic Resonance Imaging.

## Clinical use of magnetic nanoparticles

Ingrid Hilger; Institute for Diagnostic and Interventional Radiology I, Jena University Hospital, Jena, Germany.

Many different nanoparticles formulations have been developed for biomedical applications in diagnostics as well as therapy. In this context, a variety of different organic and inorganic materials are being employed. Among the inorganic formulations, iron oxide-based nanoparticles are very prominent, as they have already been introduced into clinical practice such as MRI applications. For therapeutic applications, researchers desire multifunctional nanoparticles, which combine selective targeting, diagnostics and therapy (with magnetic properties for hyperthermia treatment and/or selective drug release).

For therapeutic purposes, the utilization of magnetic nanoparticles have been proposed to effectively kill tumour cells and tumours by local thermal stress, e.g. by hyperthermia. In general, hyperthermia induces through cytotoxic temperatures pathophysiological changes on a cellular level that ultimately lead to cell death within the tumour tissue. Whole body hyperthermia is generally used for carcinomas with various metastases or heating sources are placed outside the body when employing electromagnetic waves (microwaves or radiowaves). For a more effective localized therapy within the tumour tissue, magnetic nanoparticles, consisting of a biocompatible iron oxide core (magnetite and maghemite) and a polysaccharide coating, can be deposited directly in the tumour via intratumoural application. There, their intrinsic magnetic properties are utilized to generate heat within the tumour during the exposure to an alternating magnetic field. The heating potential or specific absorption rate is defined as the amount of heat delivered per mass unit and time. Only homogeneous distributions of the injected magnetic material consistently induce hyperthermic temperatures above 43 °C within the tumour. Therefore, the control of the deposition of nanoparticle dosages and the handling of the intratumoural distribution patterns are key factors in determining the therapeutic outcome.

### **Ingrid Hilger, PhD**

Prof. Hilger is head of the Department of Experimental Radiology at the University Hospital, Jena, Germany. Born in Argentina, she studied biology at the Christian Albrechts University in Kiel, Germany, and received her diploma in 1990. She performed several studies in biology in South America and Asia. Later on, she got interested in human biology and biochemistry received her PhD at the Medical High School Hannover, Germany, in 1996. Since then, she focused her research activities to the areas of therapeutic nanotechnology and in vivo meso/macroscopic near-infrared fluorescence molecular imaging and preclinical imaging in general. Since 2008, she is full professor at the University Hospital Jena, Germany. She was awarded with the Walter Friedrich Prize in 2003. She is the spokesman of the German molecular imaging network and the German representative of the European Society of Molecular Imaging.



## New devices based on advanced imaging

Stephanie Teughels, Peter Vaes, Joeri Verbiest; Pepric nv, Leuven, Belgium.

Quantitative detection of magnetic nanolabels enables the determination of the pharmacokinetics of magnetic particle therapies through longitudinal and quantitative monitoring of the magnetic nanolabel. Newly developed contrast agents for medical imaging have to prove a positive influence on the healing prognosis. In order to receive FDA approval for use in the clinic, a higher contrast in the MRI image is not sufficient. The contrast must enable an improved therapeutic treatment of the patient. Hereto magnetic nanoparticles are now being developed as diagnostic and therapeutic agents with ligands and drugs on the outer coating of the contrast particles such as antibodies and peptides for selective targeting and drugs for target specific drug delivery.

For validation of the developed particles and coatings, it is necessary to determine the pharmacokinetics of the therapeutic and diagnostic particles in the body fluids and tissues. Quantitative distribution of the parti-

cles is key to evaluate the specificity of the targeting and efficacy of the drug delivery. Quantitative distribution of therapeutic particles will allow to

- determine the maximal effective dose concentration and optimize the dose repetition time
- reduce cost in the pre-clinical trajectory of particle therapies
- obtain a predictive value for the design of the clinical trials reducing the patient studies

The developed particle spectrometer is based on a direct and selective detection method pEPR (particle Electron Paramagnetic Resonance). When combined with MRI, the PPS offers the solution for quantitative distribution studies.

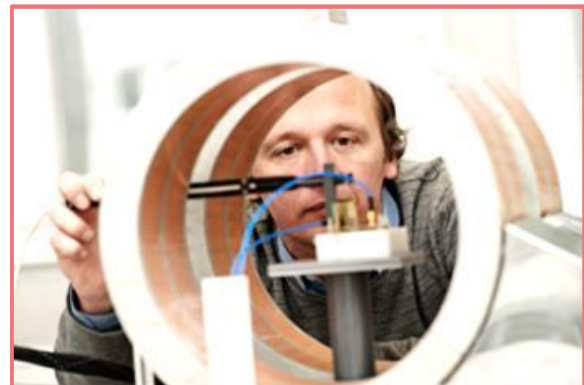
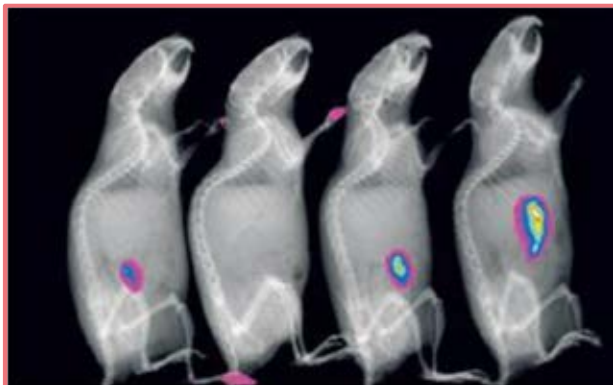

### Stephanie Teughels, PhD

Stephanie Teughels is the CEO and Founder of Pepric: she took the initiative to set-up the Pepric and now has 5 years' experience in the business development and financial aspects of the company. Previous to Pepric, she prepared and assisted spin-off projects at Imec as Venture Development Manager. During her PhD she worked at several international particle accelerator facilities (France, US, Japan) on nuclear magnetic resonance techniques. This offered her the necessary background for a clear understanding of the technological principles of MRI, PET and SPECT. Dr. Teughels has obtained postgraduate degrees in Corporate Finance (2006), Business Administration (2005), and nuclear physics (PhD, 2001).



## (III) Cluster: Targeted nanopharmaceuticals and diagnostics



*Images courtesy of the Targeted Nanopharmaceuticals and Diagnostics Cluster.*



## Overview of targeted nanopharmaceuticals and diagnostics cluster activity

Yuri Volkov; School of Medicine and CRANN, Trinity College Dublin, Ireland.

Nanomedicine promises to develop more effective, safe and cheaper therapies for patients, and to improve Europe's health system by supporting its sustainable and economic growth. This objective is mostly achieved by utilizing flexible and multifunctional approaches, technologies and tools that exploit the specific properties from the nanoworld.

Several EU funded projects are developing innovative therapies, detection and diagnosis methods in the field of nanomedicine and cover a wide variety of diseases. The 'Targeted Nano-Pharmaceuticals and Early Diagnostics' cluster brings together about 25 such research projects, funded by the EU Sixth and Seventh Framework Programmes for Research (FP6 and FP7), under the priorities NMP and HEALTH.

The projects in the cluster each have their own research objectives, but an important common element is the emphasis on the application of state-of-the-art nanotechnology. Each of them brings together specialists from 5 to 30 partner laboratories in different universities, research organizations, clinics, industries and SMEs from across Europe to collaborate on the common aim. The project consortia are also able to organise education

activities, workshops and conferences in cooperation with the other initiatives. All the research teams involved have an interest in being kept up-to-date on future regulatory requirements and procedures, in order to anticipate the likely requirements to gain market authorization for their new therapies.

The cluster activities promote further networking on a European scale, enabling researchers in the various organizations and countries to get to know and work with each other, thus contributing to the European Research Area. Furthermore, the cluster activities help to increase the visibility of individual projects as well as the importance of the research field as a whole.

The present section will show the rationale and available updates of five projects that form the cluster and are focused on different research areas of nanomedicine: 3 Micron is focused on diagnosis, NAMDIATREAM on biomarkers, NANOFOL on inflammatory diseases, MULTIFUN on breast and prostate cancer, SAVEME on cancer diagnosis and treatment. For further information on the cluster, please visit the webpage at [http://ec.europa.eu/research/industrial\\_technologies/targeted-nano-pharmaceuticals\\_en.html](http://ec.europa.eu/research/industrial_technologies/targeted-nano-pharmaceuticals_en.html).

### Yuri Volkov, MD, PhD

Yuri Volkov received his MD from the Moscow Medical University and subsequently a PhD in biomedical sciences from the Institute of Immunology, Moscow. He is a Professor at the Department of Clinical Medicine and former Director of Research at the School of Medicine, Trinity College Dublin (TCD). Prof. Volkov coordinates a large-scale EU FP-7 project, NAMDIATREAM, for early diagnostics and monitoring of malignant diseases, with 22 European academic, research, clinical and industrial partners. He is the lead TCD partner for the EU FP-7 project, MULTIFUN, and Principal Investigator on a number of other grants. Prof. Volkov is the author of over 100 scientific publications, including articles and book chapters, and he is an inventor on several patents.

## Folate-based nanobiodevices for integrated diagnosis/therapy targeting chronic inflammatory diseases

Artur Cavaco-Paulo; Department of Biological Engineering, University of Minho, Braga, Portugal.

It is estimated that inflammatory diseases affect more than **80 million people** worldwide leading to untold suffering, economic loss and premature death. Considering life expectancy in Europe, these numbers are expected to increase in the next 20 years. Moreover, **studies** have shown that disorders such as **rheumatoid arthritis (RA)** can shorten **life span by 10** years. The treatment of chronic inflammatory disorders, including RA, remains a challenge for the medical and scientific community. The emergence of new drugs creates new options though it also entails **high costs, complicated drug administration, allergic reactions** and potentially **fatal side effects**. Therefore, more efficient strategies have to be identified in order to improve inflammatory

disease treatment while decreasing the side effects with an improved cost-benefit ratio.

In this presentation are reported the last development achieved under the NANOFOL project. The consortium produced FBN (liposomal, protein-based nanoparticles) with encapsulated anti-inflammatory drugs that showed to be biologically active, non-cytotoxic and capable of specifically targeting folate receptor (FR)-positive cells. The consortium also showed that FR $\beta$  might be exclusively expressed on a certain subset of macrophages present in several types of inflammatory conditions. Special attention is being given to minimizing the use of animal testing by establishing adequate in vitro models.

### Artur Cavaco-Paulo, PhD

Artur Cavaco-Paulo has been a Professor in the Department of Biological Engineering at the University of Minho since 2012. Previously, he was at the Department of Textile Engineering of the same University, where he worked on fibre bio-based process in the last 20 years. His current research interests are on application of bio-based molecules and materials in areas of pharma, cosmetics and fibre areas. He authored more than 200 research papers, with H factor of 32, he supervised more than 25 PhD students and he keeps a group with the size 13-15 persons. He was (and it is) involved in more than 20 EU funded project since the fourth Framework program in 1995.



## SaveMe: A modular active nano-platform for advanced cancer management — Core nanosystems, tumour targeting and penetration, molecular imaging and degradome based therapy

Louis Shenkman; Tel Aviv University, Tel Aviv, Israel.

An estimated 3.2 million new cancer cases and 1.7 million deaths per year in Europe define cancer as a crucial public health problem. SaveMe is developing a novel modular nanosystems platform integrating advanced functionalized nano-core particles and active agents. The modular platform will enable the design of diverse active nanosystems for diagnostic or therapeutic applications. As a model system, SaveMe is developing and validating the platform for pancreatic cancer. Pancreatic cancer has the highest one-year mortality rate of any cancer and is Europe's sixth deadliest cancer. Most pancreatic tumours are detected late, at metastatic stage and 85% are unresectable at the time of detection. This is due, in part, to the limitation of current imaging systems in diagnostic accuracy, particularly in identifying sub-cm disease.

For early diagnosis, active nanosystems are being developed for MR, PET and gamma camera imaging. For that purpose, novel functionalized nano-core systems will be conjugated with semi-confluent active shell layer. Three types of shell layers will be designed (1) iron oxide nanoparticles as advanced MRI contrast agents; (2) DOTA complexes for MRI (with Gd<sup>3+</sup>), PET (with Ga-68) or gamma camera (with Ga-67); (3) both iron oxide nanoparticles and DOTA-Ga68 complexes for a sequential or simultaneous MR/PET imaging, as well as a novel hybrid PET/MRI prototype.

For therapeutics, active nanosystems are being developed to deliver antibodies or nucleic acids including: (1) anti-matrix metalloproteases (MMP)-inhibitory-scFv, and (2) therapeutic siRNAs. We have preliminary data in cell systems demonstrating the feasibility of our NPs as

carriers of siRNA and their effectiveness in silencing selected genes.

The nanosystems will be designed for intravenous (IV) administration. Targeting moieties will consist of tumour cell targeting peptides, including novel somatostatin receptor analogue (SSTR) subtypes and targeting moieties such as the receptor/ligand system Gal-1/tPA. The later may allow selective targeting of pre-malignant pancreatic cancer. To enable specific tumour tissue penetration, a PEG-MMP-substrate-PEG agent for optimal tissue diffusion will be used.

To date, we have designed and screened novel generic core polymeric nanosystems for optimal nano-material properties (NC average size and low size dispersivity, functionality level, water compatibility, minimal aggregation level). Polymers used are non-toxic, biodegradable and biocompatible, classified as GRAS (Generally Recognized As Safe) like PLGA (poly[lactic-co-glycolic acid] co-polymer), PEG (polyethyleneglycol) derivatives including PLGA hybrids, human serum albumin (HSA), and polyacrylates. Various nanofabrication methodologies have been explored, including polyacrylate (PAs) Huisgen "Click" cycloadditions (Intramolecular polymer single chain cross-linking/collapse), NC nanoprecipitation (solvent deposition) with oil/water emulsion and desolvation methods.

Our preliminary results showing attachment of NPs to cancer cells and intracellular penetration and silencing of selected genes with siRNAs is promising and supports the validity of the concept.

### Louis Shenkman, MD

Louis Shenkman is a professor of medicine at Tel Aviv University, Tel Aviv, Israel. He is the coordinator of the SaveMe project. Shenkman graduated from New York University School of Medicine and joined the faculty at Tel Aviv University in 1982. He was chair of the department of medicine at one of the affiliated hospitals, and he has been engaged in biomedical research all of his professional career. He currently is the medical director of Elfi-Tech Ltd., a biomedical company specializing in non-invasive medical sensors.

### **3MICRON: Multimodality microballoons**

Hans Hebert; School of Technology and Health, KTH, Sweden.

In vivo multimodality imaging is a fast growing field in medical research. Although the achievements at clinical level of this diagnostic method are recent, it is already one of the most promising approaches in the diagnosis of diseases at many research medical centres.

The 3MICRON project team gathers together scientists from some of the most advanced European medical and technical institutions to design a set of new diagnostics strategies based on advanced medical imaging, and to push the potential of this technology beyond the state-of-the-art.

Multimodality imaging is currently viewed as a simple and powerful integration of two or more imaging methods (e.g. PET-CT). In the 3MICRON project, the multimodality approach being taken is supported by a

class of next-generation micro/nanodevices called microballoons. In other imaging methods (SPECT, MRI), these subsystems at present provide the function of an ultrasound contrast agent. In the approach being taken by 3MICRON, they could act as a minimally invasive drug delivery method and hyperthermia device.

The project team will test these multi-functional microballoon devices both in vitro and in vivo in order to assess bioclearance and cytotoxicity effects toward high impact diseases, e.g. vascular and inflammation pathologies. Finally, selected types of microballoons will undergo pre-clinical screening for a consolidated assessment of the “bench-to-bed” pathway for such new microdevices.

#### **Hans Hebert, PhD**

Prof. Hans Herbert is Head of Department Professor in Biotechnology at the School of Technology and Health at the KTH, a position he has held since 2005. He obtained his Master of Technology at Uppsala University in 1975, his PhD as Doctor of Technology at Karolinska Institutet (KI) in 1979, and Docent in medical physics at KI in 1981. He has several academic and industrial positions and merits: Professor in Cryo Electron Microscopy, Lund University in 2001-2004, Research position at Swedish Natural Science Research Council in 1995-2000. He is Member of Central Promotion Review Committee, KTH, since 2005; member of Faculty Assembly, KTH, since 2009; President of Scandinavian Society for Electron Microscopy, 1998–2002; Member of the Executive Board for the European Microscopy Society, 1998 – 2004; Technical platform manager, Swegene, Lund University, 2001-2004; VR-M assessment group member, since 2009; Member of international advisory board “Ion pump consortium” Århus University, since 2007; International Advisory Board for ISDSB2007, Tokyo; International Advisory Board for 14<sup>th</sup> European Microscopy Congress, Aachen, 2008; International Advisory Board for ISDSB2010, Paris member of organizing committee for SCANDEM2001 and member of SCANDEM2010. An overall aim of his current research is to characterize, under close to native conditions, membrane related processes in living organisms. Such processes are dependent on the interplay between the barrier function of the lipids and the mechanisms of membrane proteins. Another focus is to determine structures of large macromolecular complexes in their unconstrained, physiological states, using cryo-electron microscopy.

## (IV) Imaging cell and tissue interaction with nanomaterials

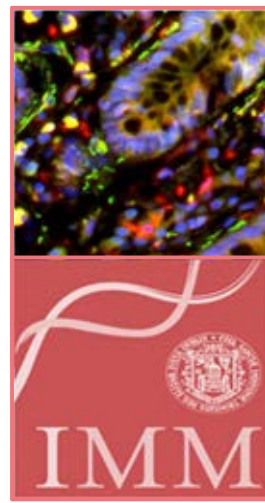
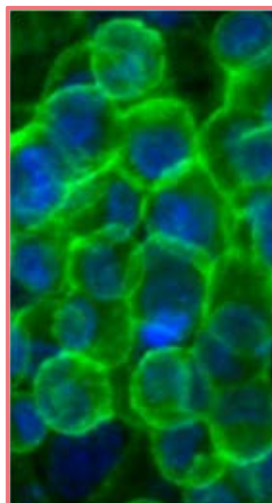
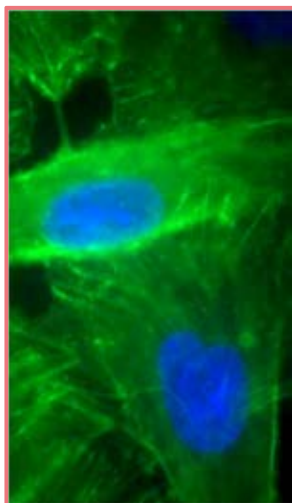
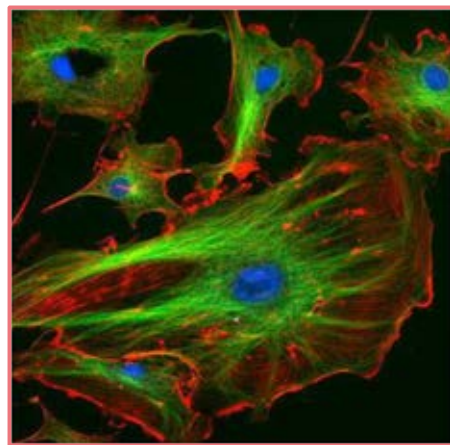
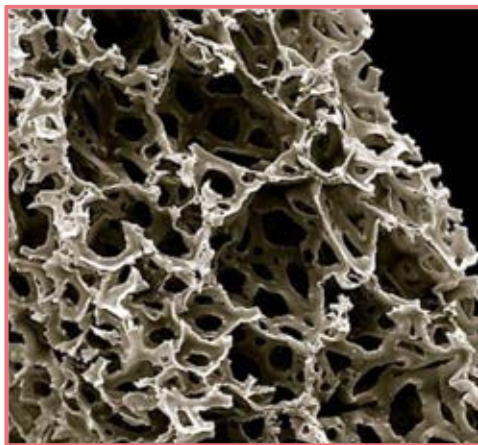

*Images courtesy of the Institute of Molecular Medicine, Trinity College Dublin.*



## Advanced models for imaging cancer

J.E. Mathejczyk<sup>1</sup>, F. Ramos-Gomes<sup>1</sup>; A.K. Wege<sup>2</sup>, W. Stuehmer<sup>1</sup>, L. Pardo<sup>3</sup>, T. Rakovich<sup>4</sup>, Y. Volkov<sup>4</sup>, A. Prina-Mello<sup>4</sup>, P. Chames<sup>5</sup>, D. Baty<sup>5</sup>, A. Sukhanova<sup>4,6</sup>, I. Nabiev<sup>4,6</sup>, F. Alves<sup>1,7</sup>; (1) Max Planck Institute for Experimental Medicine, Department of Molecular Biology of Neuronal Signals; (2) Clinic of Gynecology and Obstetrics, Caritas Hospital St. Josef, University of Regensburg, Germany; (3) Max Planck Institute for Experimental Medicine Oncophysiology group, Göttingen, Germany; (4) Institute of Molecular Medicine, Trinity College Dublin, Dublin, Ireland; (5) INSERM Centre de Recherche en Cancérologie de Marseille, Inserm UMR 1068, CNRS UMR 7258, 13288 Marseille Cedex 09, France; (6) Laboratory of Nano-Bioengineering, Moscow Engineering Physics Institute, 115409 Moscow, Russian Federation; (7) Department of Hematology and Oncology, University Medical Center, Göttingen, Germany.

The aim of the study was to validate new generation nanoparticles (NP) based on quantum dots (QDs) or on second harmonic generation (SHG) properties conjugated either to single domain antibodies or to small molecules targeting tumour associated antigens for their ability to detect tumour cells in biological samples.

For this purpose human breast, lung and pancreatic metastatic tumour mouse models were established with tumour cells expressing either human epidermal growth factor receptor 2 (HER2), human epidermal growth factor receptor (EGFR) and carcinoembryonic antigen (CEA). Human tumour cells and biological samples from orthotopic tumour mouse models were analysed by western-blot and immunohistochemistry. Human tumour cells with high, moderate and low expression of the tumour-associated antigen were identified in order to validate the specific binding capacity of the NP-conjugates to tumour cells *in vitro*. For validation of NP-conjugates to detect tumour cells within tissue or body fluids the tumour cells were implanted orthotopically

into nude mice.

In order to establish metastatic breast cancer models, HER2 positive tumour cells BT-474 cells were orthotopically implanted into nu/nu mice that had received hormone-pellets subcutaneously. HER2 negative tumour cells MDA-MB231 were used as negative controls. HER2 positive mammary carcinoma SKBR3 cells were implanted into the liver of neonatal immunodeficient NOD.Cg-Prkdcscid Il2rgtm1Wjl/SzJ mice (JAX®) that were irradiated with 1 Gy for 3 hours before transplantation. Both models resulted in a metastatic spread of tumour cells in different organs. Biological samples were collected from these tumour-bearing mice for further analysis.

By applying single domain anti-EGFR antibody conjugated to QDs we were able to stain specifically tumour cells in paraffin sections of biological samples from mice with breast tumours and metastatic spread. Furthermore, single tumours cells were detected in body fluids like ascites and blood.

### Frauke Alves, MD

Frauke Alves is Professor of Internal Medicine at the University Medical Center Goettingen (UMG). She graduated from the University of Goettingen in medicine in 1989. She was a postdoctoral fellow in the Dept. Molecular Biology (Prof. A. Ullrich), at the Max-Planck-Institut für Biochemie, Martinsried from 1991–1994, working on tyrosine kinases and cancer before moving to the Oncology and Haematology department at the UMG to establish her own scientific group alongside her clinical training. She heads a research group in the Dept. of Haematology and Oncology at the University Medicine Center, Goettingen. In addition to being a clinician, since 2008 she is leading a second research group at the Max-Planck-Institute for Experimental Medicine in Goettingen, in the Dept. of Molecular Biology of Neuronal Signals, with the aim of translating basic knowledge into clinical practice. The focus of her interdisciplinary tumour imaging group is the investigation of mechanisms of tumour progression, angiogenesis, and the development of novel anti-tumour therapies and diagnostic tools in orthotopic metastatic and transgenic tumour mouse models. Another goal is to establish novel diagnostic procedures by means of imaging in combination with new nanoparticle based probes, especially for oncology, and to optimize these for future use in the clinic.

## Nanotoxicology implications in Nanomedicine: unanswered questions and future directions

Marcello G. Cacace; Institute for the Study of Nanostructured Materials, National Council of Research (CNR), Bologna, Italy.

Almost every industrialized country has largely invested in nanotechnology-related initiatives to foster R&D in this area, which encompasses ICT, health-, food- and materials-related themes. The European Commission's contribution to this effort is of the order of €1.5 billion, deployed mainly, but not exclusively, through the execution of almost 600 nanoscience projects. The nanosafety field has witnessed a sharp increase in interest and in ensuing R&D programmes, by national and international authorities and institutions to face the problem of possible risks posed to health and environment by the widespread diffusion of the new materials.

On the other hand, the scientific community and industry have long recognized the enormous potential of exploiting the multi-faceted properties of nanomaterials and nanoparticles for improving the available assortment of tools to tackle more and more pathophysiological challenges in medicine.

Both nanomedicine and nanotoxicology are inquiring on the new, sometimes-unforeseen properties emerging from the bio-nano interaction to exploit them for improving our health on one side and to prevent and control undesired effects, on the other. Undoubtedly, at this stage nanotoxicology and nanomedicine share the common quest of a thorough understanding of the details of the bio-nano interactions.

I will present some examples taken from the recent literature, which exemplify the innovative feature of biology-inspired nanotechnology research. In fact, exploitable consequences may emerge from situations where the mere fact of touching and sampling the targeted biological entities with new materials (because of their size and properties) evoke biophysical phenomena of intrinsic peculiarity.

### Marcello G. Cacace, PhD

Besides his research activity in the field of nanotechnology, biophysics and nano-biotechnology, Dr. Cacace is currently Advisor to the European Commission, "Nano and converging Sciences and Technologies" G4 Unit, DG Research, for projects related to the fields of Nanomedicine, Nanomaterials and Nanotoxicology. He has supervised over 15 projects in the above-mentioned fields and is involved in currently running horizontal activities, such as the Nanosafety Cluster initiative, the Nanomedicine Cluster initiative and Support Actions in communication of nanotechnology research.

He has held various teaching appointments and was responsible partner in a CNR bilateral project with the Biocentrum, University of Basel, Switzerland, from 1995 to 1998, and responsible partner in a CNR bilateral project with the Institute of Biophysics, Biological Research Center, Hungarian Academy of Sciences, from 1998 to 2002. He has been the coordinator of the EU Project DNA Switch, FP5 "QUALITY OF LIFE ": QLK3-CT-2002, and has participated as a partner in the FP6 Integrated Project, CANAPE, and in two RTD-STREP Projects, NOCHEMFOOD and BIODOT. His current research interests are on the interactions of biomolecules at surfaces, functionalization and integration of cells into devices.





## Imaging cell and tissue interaction with nanomaterials: From 2D to 3D models

Dania Movia<sup>1</sup>, Adriele Prina-Mello<sup>1,2</sup>, Yuri Volkov<sup>1,2</sup>; (1) CRANN and (2) School of Medicine, Trinity College Dublin, Ireland.

In vitro risk assessment of nanomaterials commonly relies on two-dimensional (2D) cell culture systems, which do not accurately reproduce the structure, function or physiology of living tissues. In vitro three-dimensional (3D) cell culture is about creating suitable surroundings for optimal cell growth, differentiation and function. 3D cell cultures allow individual cells to maintain their normal 3D shape and structure with minimal substrate interference (i.e., reducing stress and artefacts resulting from cell adaptation to 2D growth surfaces) and they enable close imitation of the native architecture found in tissues. The life sciences market is showing a substantial need for incorporating in vivo-like cell systems (such as 3D cell cultures) in the risk assessment of chemicals and other materials. Not only there is the drive to improve the quality of data generated from in vitro assays, but

there is also the pressing demand for higher efficiency and decreased cost of the R&D process.

As part of the combined effort of the Nanosafety and Nanomedicine communities, our work is focused on the evaluation of the potential of 3D cell culture models in providing guidance on nanomaterials' safety assessment. Our studies clearly demonstrate the influence of the third dimension on cell responses when cells are exposed to nanomaterials. In particular, the simplicity, rapidity and reliability of our 3D cell model provide a breakthrough opportunity for the safety assessment of nanomaterials that can be translated into competitive market products. 3D cell models can therefore facilitate the bench-to-bedside translation of a range of new biomedically engineered biocompatible nanomaterials.

### Dania Movia, PhD

Dania Movia is a post-doctoral researcher at the Centre for Research on Advanced and Adaptive Nanostructures (CRANN)/School of Medicine of Trinity College Dublin (Ireland). In 2007, she was awarded a BSc in Medicinal Chemistry at University of Trieste (Italy). In 2011, she completed her PhD in Chemistry at Trinity College Dublin with a thesis entitled "Single-walled carbon nanotubes as novel NIR fluorescent probes for biomedical optical imaging". Currently she is involved in an EU FP7 funded projects called NANoREG, aiming at delivering the answers needed by regulators and legislators on EHS (Environmental Health and Safety) of nanomaterials.

## Raman spectroscopy in clinical diagnostics

Furio Gramatica; Fondazione Don Carlo Gnocchi ONLUS, Laboratory of Nanomedicine and Clinical Biophotonics (LABION), Milano, Italy.

Minimal Residual Disease (MRD) appears in acute leukemia patients when leukemia cells are not totally eradicated from the body even after about four weeks of chemotherapy, but the amount of malignant cells is beyond the sensitivity level of classical cytomorphic methods. Follow-up of the presence of the residual leukemia cells during chemotherapy allows a better, personalized control during the treatment, and was proved to be a powerful prognostic tool in anticipating relapse..

There are molecular biological methods available for the detection of residual blasts, but sensitive, fast and reliable MRD detection is still a challenge in establishing the follow-up process. The overexpression of the Wilm's tumour (WT1) gene transcript has been proposed as a good MRD marker in acute myeloid leukemia. The mechanism of action in case of WT1 is not completely clarified, but it was shown that WT1 overexpression leads to uncontrolled proliferation and defective differentiation of leukemia cells and has effects on the expression of other genes involved in cell-cycle promotion, differentiation and apoptosis.

Here we present the synthesis and surface modification of star shaped gold nanoparticles dedicated to Sur-

face Enhanced Raman Spectroscopic (SERS) application as analytical tool for WT1 transcript detection. A simple, gold nanoparticle synthesis method utilizing hydroquinone as reducing agent in water based reaction mixture at room temperature was optimized in order to produce gold nanoparticles for SERS application.

The Raman signal enhancing efficacy of the star shaped nanomaterial was compared with the efficacy of spherical particles. Well-known Raman reporter dyes were applied to evaluate the enhancement factor in the suspensions of star shaped and spherical gold nanoparticles with similar particle size and at the same particle concentration using various laser excitation wavelengths.

The star shaped particles synthesized with this method are easy to functionalize with thiols and also transferable into organic solvent based further modifications. The good physicochemical characteristics of these particles and the sensitivity observed in SERS experiments allow us to expect good performance in the further development steps of a novel, fast and reliable spectroscopic method for WT1 detection in MRD patients.

### Furio Gramatica, PhD

Furio Gramatica, physicist, was born in Milano in 1964. He is the Chair of the Centre for Innovation and Technology Transfer (CITT) at Don Gnocchi Foundation – an Italian chain of 30 healthcare and research centres specialized in rehabilitation – where he also leads the Nanomedicine and Clinical Biophotonics Laboratory (LABION). For five years he served as Director of the Biomedical Technology Department “Polo Tecnologico” in the same Foundation. Formerly, he spent several years at CERN (Geneva), at Italian Institute of Nuclear Physics and in high-technology companies, with R&D management roles. Dr. Gramatica is a member of the Executive Board of the European Technology Platform of Nanomedicine (ETPN) and Chair of the ETPN Clinical Interface Group; member of the board of experts, evaluators and reviewers of the European Commission and of Wellcome Trust; nanomedicine Scientific Advisor of the Italian Ministry of Health; national representative of Italy at ETPN Mirror Group; member of Nanotechnology Commissions of Assobiotec and of Milano Engineers Association; fellow professor of physics at Milan University Medical School.



## High content screening of cellular response to nanomaterials interaction as imaging and decision-making tool

Adriale Prina-Mello, Yuri Volkov; School of Medicine and CRANN, Trinity College Dublin, Ireland.

High Content Screening (HCS) has been extensively utilised in the pharmaceutical industry as decision-making tool for drug efficacy and lead-candidate titration. In the past decade, this technology has also enabled academia to embrace and develop this technique further into emerging biomedical applications. Since an increasing number of biomedical applications, both in diagnostics, therapeutics and regenerative medicine have been adopting engineered nanoparticles, there is therefore a

pressing demand for quantitative tools that inform selection of the most efficient and cost-effective of the myriad potential solutions. HCS has been shown to improve such selective decision-making processes and such systems are based on high-resolution precision subcellular imaging, which enable detection of nanoparticles within identified organelles, tracking of molecular targets within the cell and quantification of selected targets.

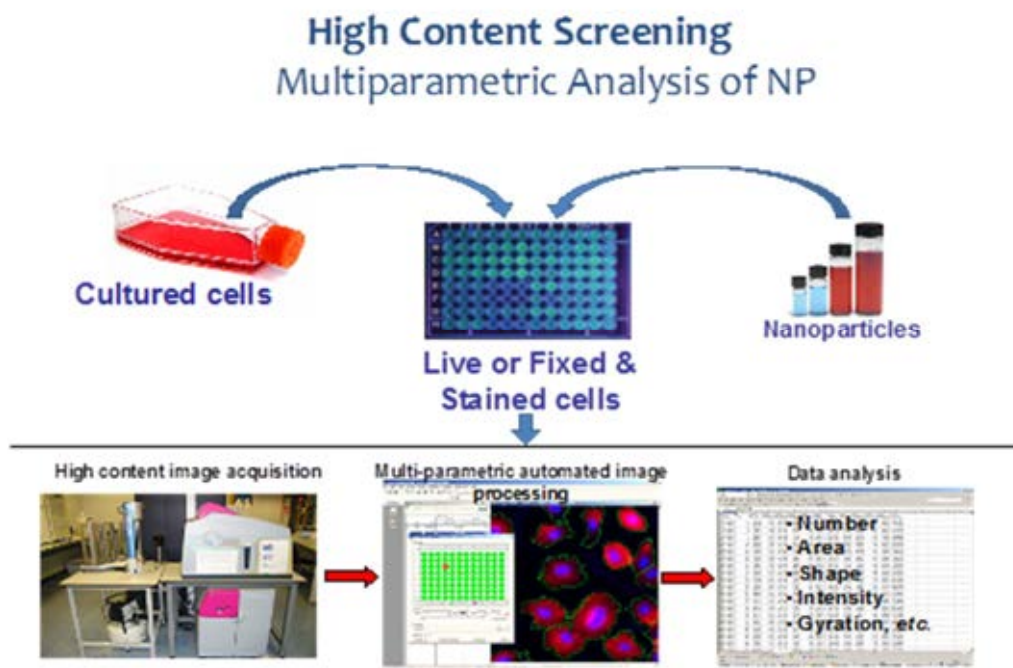

### Adriale Prina-Mello, PhD, MSc

Dr. Adriale Prina-Mello is a Senior Research Fellow at the School of Medicine, a CRANN Investigator and a part-time lecturer at Trinity College Dublin. He is also a member of the executive board of the European Technology Platform on Nanomedicine, a Nanosafety Cluster member and has recently become the National Coordinator of the NANoREG project concerning regulatory testing of nanomaterials.

Dr Prina-Mello has published extensively across many fields, including nanomedicine, nanotechnology, nanotoxicology and bioengineering. Dr Prina-Mello's main research interest is the development of future applications for nanoparticles and nanomaterials in clinically relevant biomedical and bioengineering fields.

Dr Prina-Mello is involved in developing and advancing several multidisciplinary research projects between the university, research hospital and industry partners for future applications in medicine and the nanotechnology industry. Dr. Prina-Mello is also involved in several EU FP7 funded projects: Deputy Coordinator of NAMDIATREAM (NMP), dissemination coordinator of MULTIFUN (NMP), National coordinator of NANoREG (NMP), and Science Foundation Ireland CRANN Pathfinder project.

# Winter School at Villars-sur-Ollon (2013)

Bioimaging, sensing and therapeutic applications of nanomaterials

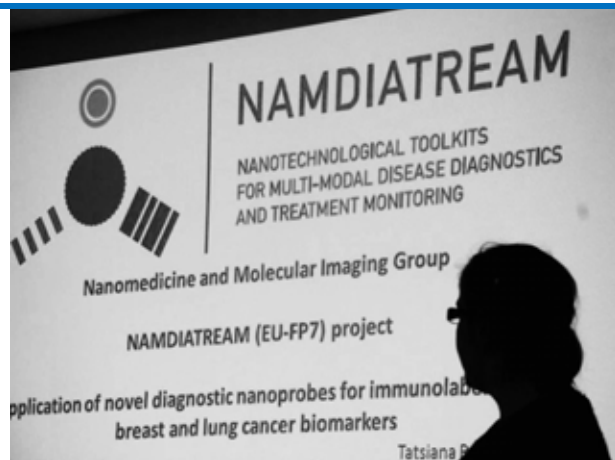



## Overview of Winter School

The NAMDIATREM Winter School, titled, “**Bioimaging, sensing and therapeutic applications of nanomaterials**”, was held in Villars-sur-Ollon (Switzerland) from 3<sup>rd</sup> – 6<sup>th</sup> March, 2013, attracting an audience of approximately 50 people, mostly PhD students and young postdocs. The school featured nine plenary speakers, renowned personalities with different scientific backgrounds from academia and industry, already appreciated by the organizers for their communication skills and the excellence of their scientific record. The format of the presentations (two hours) was chosen to provide enough time for introduction of the scientific fields to the highly multidisciplinary audience, while also allowing time for lively discussion. As a reflection of the different scientific areas converging in the implementation of nanomedicine in practice, the lecture program encompassed (i) state-of-the-art developments in optical coherent imaging and high-resolution microscopy using nanomaterials, (ii) successful applications of nanomaterials for diagnosis and drug delivery, and (iii) safety assessment of nanomaterials. The scientific presentations were also complemented by two poster sessions including a slot for short oral poster presentations (5 minutes) by young researchers and two seminars dealing with intellectual property, management of research output and funding opportunities for nanomedicine activities within the Horizon 2020 framework programme.

### Presentation Highlights

The first plenary talk, given by Prof. Yuri Volkov (Department of Clinical Medicine, Trinity College Dublin, Ireland) and titled, *Nanotechnological tools for diagnostics and therapy: Benefits and risks*, was a perfect introduction to the broad field of nanomedicine and included examples of successful research, particularly in the field of rapid cancer diagnostics. With regards to both patients and healthcare workers, Prof. Volkov highlighted the necessity of meeting stringent safety standards for nanomedical technologies.

Prof. Theo Lasser from EPFL (Switzerland) introduced the field of coherent imaging in the life sciences. His enlightening presentation, *Optical Coherent Imaging*

*from Tissue to Molecule*, was a typical example of how a timely connection made between a research community (optics) and a larger audience can promote the rapid application of state-of-the-art technological approaches to major health issues (diabetes, Alzheimer disease).

Prof. Xavier Darzacq from the Ecole Normale Supérieure in Paris (France) was a special guest from Nikon Instruments, one of the industrial supporters of the Winter School. In his talk *Single molecule imaging in the nucleus to dissect transcription regulation*, Prof. Darzacq introduced the field of superresolution microscopy, complementing the previous presentation by Prof. Lasser in terms of the length scale of investigation, in this case sub-cellular and even sub-nuclear. The image analysis he presented aimed at deciphering DNA transcription, and was based on a robust mathematical approach showing the power of mastering fundamental theoretical tools and applying them in new and diverse contexts.

Next, Prof. Patrick Boisseau from CEA-Leti, Grenoble (France) presented, *Lipidots® nanodelivery platform as Nanomedicine business case and European Technology Platform for Nanomedicine actions and policy*. Being chairman of the ETP Nanomedicine initiative, Prof. Boisseau was the perfect speaker to show the development of a new nanotechnological device, the assessment of its potential at the academic level, its introduction to the pharmaceutical industry, and finally, its development as an actual commercial product.

Prof. Colin Self's background is both academic and industrial, being affiliated with the University of Newcastle (UK), and Selective Antibodies Ltd. He is an excellent communicator and in his seminar, *Denting status quos in diagnostics and therapeutics*, he provided an enlightening historical account of the evolution of diagnostics toolkits, illustrated by a number of his own personal experiences.

Dr. Julien Nicolas from University Paris Sud 11 (France) was a special guest from BD Biosciences, an industrial supporter of the Winter School. In his talk, *Polymeric nanoparticles for drug delivery and targeting purposes*, Dr Nicolas highlighted the versatile preparation of soft nanomaterials, in particular PEGylated pol-

ymers, for the development of targeted nanocarriers. In the context of cancer and Alzheimer's disease, he demonstrated the great potential of functionalized fluorescent polymeric nanoparticles for specific interaction with malignant tissue and  $\beta$ -amyloid peptide 1-42 (monomers and fibrillar aggregates).

Dr. Frank Ludwig, from the Technische Universität Braunschweig (Germany), described the use of magnetic nanoparticles in health science. His talk, titled, *Bio-medical applications of magnetic nanoparticles: From homogeneous bioassays to imaging*, introduced the audience to the physics underlying this approach and provided numerous recent examples of their applications, including disruptive new schemes which have very recently appeared.

Dr. Samuel Constant from the company Epithelix Sàrl, Geneva (Switzerland) presented a very interesting view on *Nanomaterials and human respiratory epithelia: Old friends and new therapeutic concepts*. Apart from the scientific importance of this presentation, which concerned nano-pollution and the safety of nanotechnologies, the contribution of Dr. Constant was extremely welcome as it was proof that a young scientist with a bright idea can realize a successful product and establish a viable company in a relatively short time-span.

Dr. Alcardo Furlani from Innova SpA (Italy) led a comprehensive and highly interactive session on the management of intellectual property, entitled, *The Technology Transfer processes: Practical approaches within the NAMDIATREAM project*. The session also featured the participation of young scientists from the audience describing their business experience.

Finally, the poster sessions gathered 21 contribu-

tions by young researchers, presenting their recent achievements in the fields of: (i) nanomaterial synthesis and characterization; (ii) sensors and imaging probes based on nanodevices and (iii) diagnosis and therapeutic intervention using nanomaterials. The lively discussions, which continued late into the evening, were a very positive sign of the great interest and enthusiasm of all participants for recent developments in nanomedicine. The prize for the best poster presentation was awarded to Sebastien Courvoisier for his contribution entitled, *Substrate optimization of a nanostructured plasmonic transfection device*.

## Outcomes

The field of nanomedicine is particularly attractive but also very challenging for young scientists. On the one hand, it is easy to convey the motivation of this research to graduate and undergraduate students as it is clearly aimed at developing new and better performing diagnostic and therapeutic devices for improving people's health. On the other hand, it requires great versatility for researchers to rapidly adapt to concepts elaborated in diverse disciplines (material science, optics, biology and medicine) each one with its specific vocabulary and experimental practice. On account of the novelty of the approach, this situation is more severe in nanomedicine than in other interdisciplinary fields. The Winter School thus provided an occasion for young scientists to explore this diversity and convergence of ideas in a welcoming environment. The event was a great success in facilitating discussion and it allowed for fluent exchange (and demystification) of nanomedical concepts outside of a rigid presentation scheme.



## Program of the Winter School

### Oral Presentations

Nanotechnological tools for diagnostics and therapy: Benefits and risks

Lipidots®: Translating innovation in nanocarriers from lab to pharma – How the European Technology Platform on Nanomedicine can help you

Nanomaterials and human respiratory epithelia: Old friends and new therapeutic concepts

Single molecule imaging in the nucleus to dissect transcription regulation

Optical coherent imaging from tissue to molecule

Magnetic nanoparticle detection: From homogeneous bioassays to imaging

Polymeric nanoparticles for drug delivery and targeting purposes

Denting status quos in diagnostics and therapeutics

The technology transfer processes: Practical approaches within the NAMDIATREAM project

### Poster Presentations

Co-nanorod heterostructures

Toward a low temperature synthesis of monodisperse bismuth ferrite nanocrystals

On the Synthesis of Functionalized Bismuth Ferrite Nanocrystals

Implementation and assessment of nonlinear optical excitation in a commercial flow cytometer

Methotrexate-modified iron oxide nanoparticles: Multifunctional nano-theragnostics for MRI and drug delivery

Functionalization of nanoparticles with small targeting molecules for cancer diagnosis and imaging

Detection of magnetic nanowires using Yoke-shaped MgO-barrier magnetic tunnel junction (TMR) and GMR sensors:

Towards a magnetic cytometer

Homogenous bioassay based on specifically labeled magnetic nanoparticles in a rotating magnetic field

Homogeneous biosensor protein detection by monitoring changes in the rotational dynamics of nickel nanorods

Developing multiphoton multipurpose characterization system for biomaging materials

Nanotechnological Toolkits for the Multimodal Detection and Monitoring of Disease (NAMDIATREAM)

Application of novel diagnostic nanoprobe for immunolabelling of breast and lung cancer biomarkers

Substrate optimization of a nanostructured plasmonic transfection device

Immunoassays development for the quantification of cancer biomarkers

Kv10.1 overexpression results in cell-cell adhesion deficits and increased cell motility

Validation of tumour-specific fluorescent nanoprobe in a metastatic mouse breast tumour model

New theranostic application of second harmonic BFO nanoparticles as phototherapy tool

Bioimaging with rationally designed NIR-fluorescent nanosensors

High-Speed Tracking of Murine Cardiac Stem Cells by Harmonic Nanodoublers

Nanotoxicology screening of coated iron oxide nanoparticles: for the selection of lead candidate for theranostic applications

Imaging techniques for pancreatic ductal adenocarcinoma (PDAC) diagnostics based on Eag1 voltage gated potassium channel

# Presentation Abstracts

## Oral Presentations

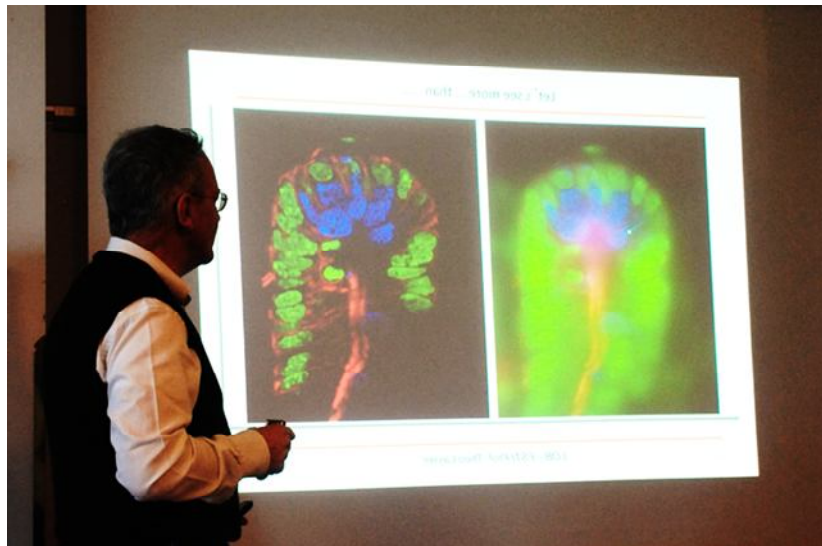





## Nanotechnological tools for diagnostics and therapy: Benefits and risks

Yuri Volkov; Department of Clinical Medicine, Trinity College, Dublin, Ireland.

In spite of the major breakthroughs in nanotechnologies in Europe and worldwide, the applications of nanomedicine as an interdisciplinary area of science to patient benefit are still in their early stages. Major efforts integrating scientists, medical doctors and industry are urgently required to bring the nanotech advances into clinics, laboratories and patients' bedside. This is a key concern in relation to the most widespread and deadly diseases, such as cancer. Regardless of the very high quality level of medical care currently achieved in the European Union member states, cancer represents a major burden on the European population in terms of morbidity and mortality. Recent advances in nanotechnology enable to establish innovative approaches to cancer detection in non-invasive and miniaturized volume formats. We will highlight here some of the latest achievements from the interdisciplinary group of European scientists (project NAMDIATREAM) focusing their efforts towards the development of complementary *in vitro* diagnostic and im-

aging techniques applicable for early stages of malignant disease onset and progression. These novel techniques are based on supersensitive "lab-on-a-bead", "lab-on-a-chip" and "lab-on-a-wire" nanodevices, utilizing the expertise of 22 partners from 9 countries across Europe including academia, clinical centres and industry. On the other hand, rapidly expanding manufacture and use of nanomaterials emphasize the requirements for thorough assessment of possible impact on human health and environment associated with novel nanoparticles and nanodevices applications. From this prospective, the approaches to safety evaluation of new nanostructures will be discussed in the talk. We will also present here how diverse types of nanoparticles can induce stress responses in human cells along with post-translational modifications of proteins *in vitro* and *in vivo* potentially leading to autoimmune disease development, unless proper containment and preventative measures are taken into account.

### Yuri Volkov, PhD, MD, MA, FTCD)

Yuri Volkov received his MD from the Moscow Medical University and subsequently a PhD in biomedical sciences from the Institute of Immunology, Moscow. He is a Professor at the Department of Clinical Medicine and former Director of Research at the School of Medicine, Trinity College Dublin (TCD). Prof. Volkov coordinates a large-scale EU FP-7 project, NAMDIATREAM, for early diagnostics and monitoring of malignant diseases, with 22 European academic, research, clinical and industrial partners. He is the lead TCD partner for the EU FP-7 project, MULTIFUN, and Principal Investigator on a number of other grants. Prof. Volkov is the author of over 100 scientific publications, including articles and book chapters, and he is an inventor on several patents.

## Lipidots®: Translating innovation in nanocarriers from lab to pharma – How the European Technology Platform on Nanomedicine can help you

Patrick Boisseau; CEA-Leti, Campus Minattec, Grenoble, France.

How does one deliver poorly soluble active pharmaceutical ingredients or contrast agents to a biological target for diagnostic or therapeutic purposes? How does one develop a nanocarrier that will catch the attention and the interest of industry in the middle of thousands solutions? How does one design a nanocarrier that should be easily approved by agencies and regulators? These questions were asked at CEA-Leti eight years ago before starting the development program of Lipidots®. Lipidots® is a versatile nanodelivery platform under development but with some first industrial applications. This lecture will review the story of the Lipidots® program run at CEA-Leti with its major milestones, successes, but also pitfalls.

There are tens of Lipidots®-like nanomedical products under development in European academic labs

or SMEs that could generate new and innovative therapies and diagnostics for the benefits of EU citizens. Developing nanomedicine as a profitable sector in Europe is the main objective of the European Technology Platform on Nanomedicine. It is setting up a comprehensive set of programs and actions in order to support an ambitious development of nanomedicine under Horizon 2020.

This lecture reviews the major actions and proposals submitted to the European Commission. The conclusion will highlight the power of the EU academic community and industry to create jobs, value and innovation at everyone's level.

### Patrick Boisseau, PhD

Dr. Patrick BOISSEAU is head of the Strategic Planning on Healthcare at CEATech and Chairman of the European Technology Platforms. Nanomedicine. Since 2008, he has been Programme Manager on nanomedicine, at CEA-Leti where 15 scientists are devoted to the preclinical and clinical development of Lipidots® lipid nanocarriers. Dr. Boisseau joined the French Atomic Energy and Alternative Energies Commission (CEA) in 1987 to work for 7 years as academic research fellow in plant biology. He then spent 4 years at the Foresight & Strategy Division at the CEA headquarters as expert on strategy in life sciences and environment. From 2001 to 2004, he was committed to the design, organization and funding of the NanoBio innovation cluster in Grenoble. From 2004 to 2008, he was coordinator of the European network of excellence in nanobiotechnology, Nano2Life. Dr. Patrick has been part of more than 12 European projects and main coordinator of 5 Framework Projects.

Other mandates of Dr. Boisseau include: Foundation of the nanobiotech section at the European Federation of Biotech in 2004; Member In 2004–2005 of the steering committee of the European Science Foundation Forward Look on Nanomedicine, responsible for the working group on “nanodiagnostics”; Chairman, since late 2012, of the European Technology Platform on Nanomedicine; Board Member in charge of Development of the European Platform on Photo-Dynamic Medicine since 2011; Experts for several international organizations such as the European Science Foundation, and the European Commission. Reviewers of numerous articles; Co-Editor of the 2007 book *Nanoscience: Nanobiotechnology and Nanobiology*, with Philippe Houdy and Marcel Lahmani (2010 in English); Editorial Board member of *Nanomedicine: Nanotechnology, Biology and Medicine* since June 2010.



## Nanomaterials and human respiratory epithelia: Old friends and new therapeutic concepts

Samuel Constant, Ludovic Wiszniewski, Song Huang; Epithelix Sàrl, Plan-les-Ouates, Geneva, Switzerland.

We are all exposed every day to ultra-thin or nano airborne particles, and the increasing population of those suffering from respiratory disease such as asthma; chronic obstructive pulmonary disease is alarming. Is there a link? Nanomaterials are considered as substances of higher risk, at the same level as carcinogens, mutagens and toxic chemicals for reproduction. However, until now there is no validated *in vitro* cell model and method for identifying the respiratory toxicity for nanomaterials.

In this presentation, we will review the most promising *in vitro* methods used for the detection of toxic effect of particles in general with an emphasis on Nanomaterials. Most of the *in vitro* cell models for long term testing of chemicals suffer of at least two shortcomings: (1) The failure of reproducing the *in vivo* physiological characteristics of the corresponding tissues and (2) a limited shelf life. To overcome these drawbacks, we developed a standardized 3D Air-liquid Interface *in vitro* cell model of the human airway epithelium (MucilAir™).

MucilAir™ is morphologically and functionally differentiated and it can be maintained at a homeostatic state for more than one year. The typical ultra-structures of the human airway epithelium, such as tight junctions, cilia, mucus, basal/goblet/ciliated cells can be observed. Classical airway transporters, ion channels and CypP450s are expressed and functional up to one year. The epithelia react to pro-inflammatory mediators in a physiological manner. The epithelia can be stimulated regularly with inflammatory substances to simulate chronic inflammatory reactions, up to several months. A large panel of cytokines/chemokines/metalloproteinases has been detected in MucilAir™.

Due to its unique long shelf-life of one year, this model is used for studying the human respiratory diseases, and for testing the long-term/chronic effects of drugs/chemicals on respiratory tract *in vitro*. Several applications of MucilAir™ will be presented with a focus on nanomaterials.

### Samuel Constant, PhD

Dr. Samuel Constant is a co-founder and the Chief Operating Officer of Epithelix (<http://www.epithelix.com>), a Swiss biotech company specialized in tissue engineering. Epithelix is a leader for *in vitro* assessment of drug efficacy and toxicity on human respiratory tract. Epithelix has developed unique 3D *in vitro* human airway tissues and testing services for studying airway pathologies like Asthma, Cystic Fibrosis and Chronic Obstructive Pulmonary Diseases. Samuel is in charge of global management and business development of the company; he also deals with the external collaborations with private and public research groups and financial issues.

Within the past 6 years, Dr. Samuel Constant and his team have focused their research efforts on the development of novel *in vitro* approaches to study effect of inhaled xenobiotics on the human respiratory tract. His efforts have led to the development of methods for repeated toxicity testing of xenobiotics (90 Days repeated dose exposure), evaluation of respiratory absorption and metabolism, assessment of lung inflammation, as well as novel *in vitro* assays for identifying the respiratory sensitizers. Since 2006, Dr. Samuel Constant and his team have won 14 prizes for their scientific achievements, technological innovation, and business development.

## Single molecule imaging in the nucleus to dissect transcription regulation

Xavier Darzacq; Functional Imaging of Transcription, Institut de Biologie de l'Ecole Normale Supérieure (IBENS), CNRS UMR 8197, Paris, France.

While membranes do not compartmentalise the nucleus, it shows a complex organization at many scales. Spatial organization of chromatin and transcription factors can modulate nuclear functions and in order to study this relation, we have developed methods to localise proteins and mRNAs at the single molecule level and with spatial resolutions in the range of a few nanometers (modifications and improvements of PALM, sptPALM and STORM using adaptive optics). Moreover, proteins move

throughout the nucleus by diffusion, transiently and repetitively contacting their target sites. While DNA has been reported as a guide facilitating target search in the cell by restricting 3-dimensional explorations to a 1-dimensional search, such exploration modes were not envisioned mediated by protein-protein interactions. I will discuss chromatin and RNA polymerase II organization in the nucleus as well as mechanisms guiding proteins to their targets in the nucleoplasm.

### **Xavier Darzacq, PhD**

Dr. Darzacq is the Principal Investigator of the "Functional imaging of Transcription" team at the Ecole Normale Supérieure in Paris. His group develops advanced imaging techniques to visualize and quantify single-molecule dynamics in live cells, with the ultimate goal of deciphering the rules governing transcription regulation within a living cell. Dr. Darzacq attained his Ph.D with Dr. Tamas Kiss at the University of Toulouse where he discovered the first function of Cajal bodies. In 2002, Dr. Darzacq joined the Laboratory of Dr. Robert Singer, at Albert Einstein College of Medicine (New York, USA) to be trained in light microscopy techniques for single molecule imaging in live cells. During his post-doctoral studies, he developed imaging technologies using genetically encoded fluorescent tags to follow transcription. Dr. Darzacq then moved to Olivier Bensaude's Lab at IBENS (Paris), where he spent two years. In 2008, Dr. Darzacq set up his own team at IBENS to study how chromatin structure and nuclear architecture regulate transcription. His group has developed strong partnerships with industry focusing on the implementation of new technologies to the field of imaging single molecules.



## Optical coherent imaging from tissue to molecule

Theo Lasser: Laboratoire d'Optique Biomédicale, Ecole Polytechnique Fédérale de Lausanne, Lausanne, Switzerland.

Imaging is key for medical diagnosis and provides new insights for the life sciences. Tissue, cell and subcellular structures can all be visualized using optical microscopy and so provide a variety of information with high spatial resolution. Structural information complemented by the functional information made possible by new optical techniques like Fourier Domain Optical Coherence Tomography (FDOCT), Doppler Imaging and extended-focus Optical Coherence Microscopy (xf-OCM) Dark field Co-

herence Microscopy (df-OCM), and its latest extension photothermal optical lock-in Coherence Microscopy (poli-OCM) which allows extending these methods into the cellular dimensions.

We will present selected examples ranging from retina blood flow, diabetes, Alzheimer's disease to brain research with an emphasis on the underlying optical concepts.

### Theo Lasser, PhD

Theo Lasser is full professor at the Ecole Polytechnique Fédérale de Lausanne and is heading the Laboratoire d'Optique Biomédicale (LOB). He and his team investigate mainly novel optical imaging techniques.

A particular research focus is on functional imaging, the development of coherent imaging methods and their application in medicine and life sciences. Low coherence microscopy (OCM) and high speed Laser Doppler Imaging (LDI) with applications in diabetes; neuroscience and infectious diseases represent the core of his current research interests. Fluorescence microscopy and spectroscopy and in particular super-resolution imaging (SOFI) applied to cell imaging complement this research.

Besides numerous publications and patents, he cofounded two companies AIMAGO and ABIONIC, which are providing innovative medical instrumentation. Before joining EPFL in 1998 he pursued an industry career at Carl Zeiss starting in the central research division and later heading the R&D in ophthalmology. In his last assignment as director of Carl Zeiss Research Center, Jena, he initiated various research projects in optics and innovative instrumentation.

## Magnetic nanoparticle detection: From homogeneous bioassays to imaging

Frank Ludwig: Institute of Electrical Measurement and Fundamental Electrical Engineering, Technical University Braunschweig, Braunschweig, Germany.

There is a wide field of potential applications of magnetic nanoparticles (MNP) in medicine and bioanalysis. Advantages of MNP as labels are that they are stable and non-toxic (at least iron oxide), that they can be manipulated by magnetic field gradients, and that they can be used in opaque media, such as blood. Iron oxide MNP have been established for years as contrast agent in MRI and in magnetic separation. Other promising applications include magnetic drug targeting, magnetic hyperthermia – both being important in cancer therapy – and imaging techniques such as Magnetic Particle Imaging (MPI). In addition, several approaches for the realization of homogeneous bioassays were proposed. Homogeneous assays have the advantage that no washing steps of unbound markers are required.

This talk will give an overview about the various approaches to realize homogeneous bioassays with magnetic markers. In addition, a short introduction into Magnetic Particle Imaging (MPI) will be given, a novel technique with the potential for real-time imaging of the spatial distribution of magnetic markers.

Homogeneous bioassays using superparamagnetic nanoparticles as markers rely on the change in dynamic properties when the markers are bound to the biological target of interest. The specific binding of the MNP to the biological target, e.g., by coupling of an antibody to an

antigen or via a streptavidin-biotin binding – can either cause a change from Brownian to Néel relaxation (if the MNP are completely immobilized or bound to rather large targets such as bacteria) or an increase in the Brownian relaxation time which is proportional to the hydrodynamic volume of the particle. Practical realizations of homogeneous assays include the measurement of the complex (ac) susceptibility, magnetorelaxometry (MRX), measurements of the phase shift between a rotating magnetic field and the net magnetization, frequency mixing techniques, and magnetic particle spectroscopy (MPS) which can be considered as a 0D MPI system. Since the signal provided by MNP suspensions is rather low (typically in the sub-nT range), highly sensitive magnetic field sensors are required. Therefore, mostly SQUIDs, fluxgates and induction coils are involved. Alternatively, the detection can be realized optically.

A novel and promising imaging technique, the so-called Magnetic Particle Imaging (MPI), was introduced in 2005 by Gleich and Weizenecker (Nature 435, 1214). MPI relies on the nonlinear magnetization curve of superparamagnetic nanoparticles and allows the real-time imaging of MNP distributions with a spatial resolution of  $\approx 1$  mm. A short introduction into the MPI principle and some first imaging examples will be presented.

### Frank Ludwig, PhD

Dr. Frank studied physics at Humboldt University Berlin from 1980 to 1985 and he continued as a researcher at the university until 1992, receiving his PhD (physics) in 1987 on magneto-optical effects in InSb bicrystals and then working as scientific collaborator at Department of Physics. From 1992 to 1995, he was a research associate at the Department of Physics at the University of California, Berkeley, in the group of John Clarke. From 1995 to 2001, he was scientific collaborator at Physikalisch-Technische Bundesanstalt (PTB) in Berlin, before taking on his current role as senior scientist at the Institute of Electrical Measurement and Fundamental Electrical Engineering at TU Braunschweig. Dr. Frank is author and co-author of more than 130 papers and book chapters and is co-author of one chapter in "The SQUID Handbook".



## Polymeric nanoparticles for drug delivery and targeting purposes

Julien Nicolas; University Paris-Sud 11, Chatenay-Malabry, France.

After a brief introduction concerning the use of nanoparticulate systems for drug delivery, the presentation will focus on recent achievements in the field of biodegradable/biocompatible polymeric nanoparticles for drug delivery and targeting purposes. In particular, two recent, promising systems will be emphasized: (i) poly(alkyl cyanoacrylate) nanoparticles against cancer and Alzheimer's disease,<sup>1,2</sup> and (ii) nanoparticles from well-defined polymer prodrug amphiphiles.<sup>3</sup>

1. Brambilla, D.; Verpillot, R.; Le Droumaguet, B.; Nicolas, J.; Taverna, M.; Kóňa, J.; Lettiero, B.; Hashemi, S. H.; De Kimpe, L.; Canovi, M.; Gobbi, M.; Nicolas, V.; Scheper, W.; Moghimi, S. M.; Tvaroška, I.; Couvreur, P.; Andrieux, K. *ACS Nano* 2012, 6, 5897.
2. Le Droumaguet, B.; Nicolas, J.; Brambilla, D.; Mura, S.; Maksimenko, A.; De Kimpe, L.; Salvati, E.; Zona, C.; Airoidi, C.; Canovi, M.; Gobbi, M.; Noiray, M.; La Ferla, B.; Nicotra, F.; Scheper, W.; Flores, O.; Masserini, M.; Andrieux, K.; Couvreur, P. *ACS Nano* 2012, 6, 5866.
3. Harrisson, S.; Nicolas, J.; Maksimenko, A.; Bui, D. T.; Mougín, J.; Couvreur, P. *Angew. Chem., Int. Ed.* 2012, DOI. 10.1002/anie.201207297.

### Julien Nicolas, PhD

Dr. Nicolas is CNRS researcher at Univ. Paris-Sud at Institut Galien Paris-Sud, in the group of Pr. P. Couvreur. In 2001, he earned his Master's degree in Chemistry and Chemical Engineering ("Ingénieur") at the Ecole Supérieure de Chimie Organique et Minérale (ESCOM) and Master 2 degree in Chemistry and Physical Chemistry of Polymers in 2002. In 2005, he earned his PhD in Chemistry and Physical Chemistry of Polymers in the Laboratory of Polymer Chemistry, University Pierre and Marie Curie, Paris. In 2010 he received a scientific excellence award from CNRS and was co-organizer of the EWPS 2010 (European Workshop on Particulate Systems) congress. In 2010 he was guest editor for *Int. J. Pharm* and since 2012, advisory board member of *Polymer Chemistry*. Since 2011, Dr. Nicolas has been web blogger for *Polymer Chemistry*. He is author of more than 50 papers, 1 editorial, 7 book chapters and 4 patents.

## Denting status quos in diagnostics and therapeutics

Colin Self; Selective Antibodies Ltd, Newcastle, UK.

There are very many obstacles to progress — technical, political, cultural and personal. This is because people are used to doing something in one way or another, think the problem is too large to address or simply don't want to take any risk. They may also feel “The boss won't let me do it” or, even worse, “I couldn't be bothered!”. This all happens on personal, institutional and governmental levels across the massive industrial sector that we call “Science”. So, the big surprise is that anything ever moves at all!

These two short lectures are aimed at providing my own small reflection on this, with respect to the scientific problems that over the years have given me, in equal

parts, an enormous amount of frustration and satisfaction. These go from the diagnostic to therapeutic areas. I will first discuss the obstacles of replacing the excellent gold standard of radio-immunoassay, through to a discussion of the limitations of ligand-receptor based assays for the critically important class of small molecular weight analytes, and how these were overcome. Finally, the very real problem of limited specificity with respect to therapeutic agents, such as monoclonal antibodies – the very fact of which it appears many would still not even like to talk about - will be discussed, with ways of dramatically improving these exciting therapeutic agents.

### Colin Self, MD, PhD

Professor Colin Self has a wide medical and scientific background. He holds the following qualifications: BSc (Chemistry), PhD (Biochemistry), DSc (awarded for work in Analytical Science), MB, BChir (Cambridge University Medical School) and is a Chartered Chemist, Fellow of the Royal Society of Chemistry and Fellow of the Royal College of Pathologists, Member of the Association of Clinical Biochemists and Fellow of the Royal Society of Medicine. Following his first degree in chemistry, he obtained a PhD in Metabolic Biochemistry and then went to the USA, and subsequently, to a Max Plank Institute in Tübingen to undertake research into immunology, immunogenicity and immunodiagnostics. He returned to the UK to a lectureship during which he wrote an undergraduate textbook on immunology. Following this, he studied Medicine at Cambridge University followed by hospital appointments in Gastroenterology, General Surgery, Rheumatology, Respiratory Medicine and Oncology. He was appointed Registrar, and subsequently Senior Registrar, in Chemical Pathology at The Hammersmith Hospital Royal Postgraduate Medical School, London and then head of the large NHS-University Department of Clinical Biochemistry of Newcastle University. During his time as a medical student, he invented and patented the technology of Enzyme Amplification, allowing the great amplification of signal (and thus speed and sensitivity) from immunodiagnostic and genetic tests. From this technology, one of the first profitable Cambridge biotechnology companies, IQ Bio Ltd - of which he was Research Director, grew rapidly while he was a junior doctor. His diagnostic research interests then centred on the development of means for the rapid, highly sensitive detection and quantification of small molecular weight analytes such as medicaments, drugs of abuse, toxins, hormones etc. From this, he developed the anti-immune complex and selective antibody systems. In parallel to this diagnostic work he has focussed on ways of making therapeutic antibodies more specific for their intended cancer targets. His group was the first to describe the activation of antibodies by light – a technology that can dramatically increase the functional specificity of antibodies by making them, in essence, regionally specific within the body and thus leaving the rest of the body unharmed.





## The technology transfer processes: Practical approaches within the NAMDIATREAM project

Aleardo Furlani, Tommaso Foglia; INNOVA S.p.A., Rome, Italy

The valorization of knowledge through technology transfer (TT) is changing face. More and more TT is carried out through collaborative actions, consortia and patent pools rather than just through bilateral licensing agreements. Opportunities and risks of this new trend are emerging.

While tangible assets decrease their value as they are used, knowledge assets increase their value through their continuous use and exchange: ideas generate new ideas, and shared knowledge enriches both the owner and the receiver. Thus, in a world of rapid changes, knowledge spillover plays a very important role for the growth. Therefore, organizations positioned at the crossroads of technology information exchanges networks,

events, web-based communities, informal groups are best placed to benefit from the knowledge transactions and gain competitive advantage.

TT is not simply a licensing contract or information dissemination: TT is a complex value proposition having to do with the integration of services (training, technical assistance, coaching, communication, marketing) and a product (a technology, a patent, a prototype). Therefore, TT requires a proactive approach leading to a tailor made outcome to fulfil the specific end-user needs. It implies a high degree of interaction and trust between technology providers and users and this interaction can take a variety of organizational and contractual forms.

### ***Contents and objectives of the seminar***

- The seminar presented new ways to generate synergies and deal-flows enhancing technology transfer in complex collaborative environments including technology buyers, R&D suppliers and SMEs.
- Risks and opportunities related to the development of public-private collaborations; roles and competences of the different involved actors; Management of the intellectual property, specifically: (i) how to manage the relationship between public and private bodies, (ii) main models of Technology Transfer (licensing, research contracts, spin-off, mobility of researchers, etc.), (iii) public-private experience of Technology Transfer.

The seminar provided hints to research organizations and industries in order

- to identify new approaches to enhance Research – Industry cooperation,
- to show ways to foster collaboration in bringing applications to the market.

### **Aleardo Furlani, MBA, MSc**

CEO and founder of INNOVA S.p.A., Aleardo Furlani holds an MBA from IESE-Barcelona. He was senior associate for MAC Group/GEMINI Consulting Group from 1987 to 1992 and then, in 1993, he set up the company INNOVA to help EU companies and Universities to implement strategies for exploitation of their R&D activities. Today, the INNOVA group has more than 150 employees and branches in Italy, USA, Luxembourg, Poland, UK, Spain and Belgium; it integrates R&D laboratories and a seed capital company. With over 20 years of experience, Mr. Furlani has a significant track record in business strategy, international marketing, innovation financing, exploitation of research results, and has delivered worldwide coaching and training sessions on transnational technology transfer, marketing, business strategies, innovation policies, project financing, leadership and communication.





## Co-nanorod heterostructures

K. Soulantica<sup>1</sup>, S. Lentijo Mozo<sup>1</sup>, B. Cormary<sup>1</sup>, T. Hungria Hernandez<sup>1</sup>, R. Tan<sup>1</sup>, C. Gatel<sup>2</sup>, M. Rodriguez, Castillo<sup>1</sup>, N. Liakakos<sup>1</sup>, J. Maynadié<sup>1</sup>, F. Wetz<sup>1</sup>, T. Blon<sup>1</sup>, M. Respaud<sup>1</sup>, A. Falqui<sup>3</sup>; (1) Laboratoire de Physique et Chimie des Nano-Objets, Toulouse, France; (2) Centre d'Elaboration de Matériaux et d'Etudes Structurales, Toulouse, France; (3) Instituto Italiano di Tecnologia, Genova, Italy.

An emerging direction in nano-sciences is the transition from simple component inorganic nano-crystals to multi-functional hetero-structured nano-objects in which chemically different domains coexist on the same object.<sup>1</sup> The resulting nano-objects may combine the properties of each one of their components, but they can also present new unexpected properties due to the interaction between the different materials. Apart from alloys, which have a homogeneous composition, hetero-structured nano-crystals can adopt two general topological structures. One structure is what we call core@shell nano-crystals in which two or more materials are arranged concentrically in an onion-like structure. On the other hand, asymmetric oligomers are formed when two or more domains are connected together through a small interface.

Anisotropically shaped metallic Co nano-crystals present a high Ms and a high coercive field, which makes them ideal candidates for applications that need mag-

netically hard materials. We present hetero-structured nano-objects prepared by using Co nano-rods as seeds in order to grow other materials on them in a topologically controlled fashion. By judicious choice of the experimental conditions, we can have access to heterostructured<sup>2</sup> or core@shell with various metals. Alternatively, we can impose the anisotropic growth of Co nano-crystals starting from seeds of other materials.<sup>3</sup>

1. P.D. Cozzoli, T. Pellegrino, L. Manna, *Chem. Soc. Rev.* 2006, 35,1195
2. F. Wetz, K. Soulantica, A. Falqui, M. Respaud, E. Snoeck B. Chaudret, *Angew. Chem. Int. Ed.*, 2007, 46, 7079-7081
3. J. Maynadié, A. Salant, A. Falqui, M. Respaud, E. Shaviv, U. Banin, K.Soulantica, B. Chaudret *Angew. Chem. Int. Ed.*, 2009, 48, 1814.

## Toward a low temperature synthesis of monodisperse bismuth ferrite nanocrystals

G. Clarke<sup>1,2</sup>, A. Prina-Mello<sup>1</sup>, Y. Mugnier<sup>2</sup>, R. Le Dantec<sup>2</sup>, Y. Volkov<sup>1</sup>; (1) School of Medicine and CRANN, Trinity College Dublin, Ireland; (2) Université de Savoie, Laboratoire Symme, Polytech'Annecy-Chambery, France.

Bismuth ferrite (BFO) is a very attractive crystal for its magneto-electric, piezoelectric and nonlinear optical properties. Recent advances in nonlinear microscopy and deep-tissue imaging have accelerated worldwide interest in BFO because it is a near-ideal candidate for these applications. Research has however been limited by the difficulty in determining a scalable, facile synthesis route which yields nanoscale, monodisperse and monocrystalline BFO. In this poster, we analyse four major synthesis parameters, which affect BFO's size, polydispersity and crystallinity using the solvent evaporation method; these are chelating agent, the use of a dispersion medium (salt), the time and the temperature of annealing.

BFO nanoparticles were prepared by Ghosh et al's ferrioxalate precursor method. To improve crystallinity at lower temperatures, a range of chelating agents was explored, including those represented in the literature (oxalic acid and tartaric acid). To separate the particles during annealing and hence reduce their size, the metal-

organic precursor was annealed in excess NaCl. To investigate the effect of temperature and duration on size and polydispersity, the temperature was varied from 300-500°C and annealing was carried out from ten minutes to two hours.

Analysis was carried out by XRD, SEM, TEM, zeta potential measurement and photocorrelation spectroscopy. The nonlinear optical response was measured by probing solutions of suspended nanoparticles with an Nd:YAG laser to determine the ensemble Hyper Rayleigh Scattering signal.

Initial results indicate that these four parameters significantly affect the size, size distribution and crystalline structure of the as-synthesized nanoparticles and strongly indicate a novel route for a fast, scalable synthesis of highly crystalline nanoscale bismuth ferrite. This has potential for wider application to the synthesis of other nanocrystals.

## On the Synthesis of Functionalized Bismuth Ferrite Nanocrystals

S. Schwung<sup>1,2</sup>, D. Rytz<sup>1</sup> and T. Jüstel<sup>2</sup>; (1) Forschungsinstitut für Edelsteine und Edelmetalle (FEE) GmbH, Idar-Oberstein, Germany; (2) Muenster University of Applied Sciences, Steinfurt, Germany.

A Néel temperature of 643 K<sup>1</sup> and a ferroelectric Curie temperature of 1103 K<sup>1</sup> make Bismuth ferrite (BFO) to date the only known room temperature multiferroic material. It should be noted that single phase BFO, neither in powder nor single crystal form, is rare and not easily obtained. Recent studies even discuss phase impurities in BFO as the extrinsic source of the magnetic properties of BFO<sup>2,3</sup>.

This study is focused on the elimination of the secondary phases in BFO and the preparation of nanocrystals with a definite particle size and a monodisperse particle size distribution (PSD). A routine protocol for BFO synthesis with minimized second phases and narrow PSD was developed, based on combustion synthesis. In addition, magnetic properties were improved by shell layers added around BFO cores. Different techniques such as precipitation of magnetic iron oxide onto BFO nanocrystal seeds or growth of iron oxide on BFO prepared in high temperature boiling solvents were used. A series of experiments with various reagents of bismuth and iron, various sol gel agents or different solvents and annealing procedures were investigated.

The resulting multiferroic nanocrystals were characterized by standard techniques (x-ray diffraction, dynamic light scattering, scanning electron microscopy and hyper-Rayleigh scattering). First results of core-shell BiFeO<sub>3</sub>@Fe<sub>3</sub>O<sub>4</sub> particles show improved magnetization behavior.

1. Kumar, A.; Rai, R. C.; Podraza, N. J.; et. al: "Linear and nonlinear optical properties of BiFeO<sub>3</sub>", Appl. Phys. Lett. 92 (2008) 121915
2. Guo, R.; Fang, L.; Dong, W.; et. al: "Magnetically separable BiFeO nanoparticles with a  $\gamma$ -Fe<sub>2</sub>O<sub>3</sub> parasitic phase: controlled fabrication and enhanced visible-light photocatalytic activity", J. Mater. Chem. 21 (2011) 18645
3. Mazumder, R.; Sujatha Devi, P.; Bhattacharya, D.; et. al: "Ferromagnetism in nanoscale BiFeO<sub>3</sub>", Appl. Phys. Lett. 91 (2007) 062510

## Implementation and assessment of nonlinear optical excitation in a commercial flow cytometer

H. Lemopoulos, T. Magouroux, A. Rogov, L. Bonacina, J.-P. Wolf; Université de Genève, Geneva, Switzerland.

Flow cytometry is a well-known technique, often used in biology and medicine, allowing detection of fluorescing species in fluids for studying cell population, protein expression, etc. An extension of this technology to nonlinear optics can bring increased detection sensitivity, as shown in a recent work demonstrating simultaneous second and third harmonic detection in a nonlinear correlation spectroscopy apparatus.[1] We are presently working on an adaptation of this novel approach to a

commercial flow-cytometer. We present our system in details and discuss the preliminary performance tests based on nonlinear harmonic nano- and micro-particles.

1. M. Geissbuehler, L. Bonacina, V. Shcheslavskiy, N.L. Bocchio, S. Geissbuehler, M. Leutenegger, I. Märki, J.-P. Wolf and T. Lasser, Nano Letters, 2012, 12, 1668-167



## Methotrexate-modified iron oxide nanoparticles: Multifunctional nano-theragnostics for MRI and drug delivery

A.M. Abdelmonem<sup>1</sup>, S. Sánchez Paradinas<sup>1</sup>, D. Sasse<sup>2</sup>, N.C. Bigall<sup>1</sup>, Wolfgang Parak<sup>1</sup>; (1) Fachbereich Physik, Philipps Universität Marburg, Marburg, Germany; (2) Klinik für Strahlendiagnostik AG Medizinische Physik, Universitätsklinikum Giessen und Marburg GmbH, Standort Marburg, Germany.

Nanomaterials combining different functionalities within one entity known as multifunctional nanoparticles offer exceptional and promising prospects in many disciplines especially fundamental biology and biomedical applications like imaging, diagnosis and drug delivery. A variety of nano-theragnostics combining several diagnostic (e.g. magnetic resonance imaging, radioactivity and fluorescence) and therapeutic (e.g. targeted drug delivery and hyperthermia) features are currently under intensive investigation in nanomedicine<sup>1-4</sup>.

In this work, superparamagnetic iron oxide nanoparticles (MNPs) were synthesized in a non-polar solvent and coated with an amphiphilic polymer in order to transfer them into aqueous solution according to the procedure of Pellegrino et al.<sup>5</sup> obtaining water soluble polymer coated magnetic nanoparticles with free carboxylic groups which provide versatile platforms for subsequent surface modifications and bio-conjugation. Subsequently, the polymer coated iron oxide nanoparticles were modified with 2 kilo- Dalton polyethylene glycol yielding PEG modified MNPs with free amine groups on the surface. In the next step, methotrexate (anticancer drug widely used for treatment many types of cancers) was attached to the free amine groups on the surface of the magnetic NPs via amide bonds using EDC chemistry yielding a multifunctional magnetic nanoparticles. This methotrexate-MNPs bio-conjugate provide water soluble magnetic iron oxide nanoparticles expected to serve as

multifunctional-nanotheragnostic for diagnostic (MRI contrast enhancing agent) and therapy via targeted drug delivery and release of the methotrexate therapeutic agent and possibly hyperthermia.

1. Di Corato, R., N. C. Bigall, et al. (2011). "Multifunctional Nanobeads Based on Quantum Dots and Magnetic Nanoparticles: Synthesis and Cancer Cell Targeting and Sorting." *Acs Nano* 5(2): 1109-1121.
2. Hariri, G., M. S. Wellons, et al. (2011). "Multifunctional FePt Nanoparticles for Radiation-Guided Targeting and Imaging of Cancer." *Annals Of Biomedical Engineering* 39(3): 946-952.
3. Kim, K., J. H. Kim, et al. (2010). "Tumour-homing multifunctional nanoparticles for cancer theragnosis: Simultaneous diagnosis, drug delivery, and therapeutic monitoring." *Journal Of Controlled Release* 146(2): 219-227.
4. Sanvicens, N. and M. P. Marco (2008). "Multifunctional nanoparticles - properties and prospects for their use in human medicine." *Trends In Biotechnology* 26(8): 425-433.
5. Pellegrino, T., et al. (2004) "Hydrophobic nanocrystals coated with an amphiphilic polymer shell: a general route to water soluble nanocrystals". *Nano Letters*. 4(4): 703-707.

## Functionalization of nanoparticles with small targeting molecules for cancer diagnosis and imaging

S. Passemard<sup>1</sup>, D. Staedler<sup>1</sup>, L. Juillerat-Jeanneret<sup>2</sup>, S. Gerber-Lemaire<sup>1</sup>; (1) ISIC, Ecole Polytechnique Fédérale de Lausanne, Batochime, Lausanne, Switzerland; (2) University Institute of Pathology, CHUV, Lausanne, Switzerland.

Medical imaging is a major tool for the prevention and the detection of cancer. The development of nanotechnology-based medical diagnostic tools could provide a qualitatively new level of sensitivity and accuracy for the detection of malignant diseases. Here, the synthesis of functionalized nanomaterials with small targeting molecules that can capture cell entities for the detection of breast and lung cancers has been investigated (Scheme 1).

The synthesis of multivalent ligands for the specific targeting of cancer cells biomarkers and their conjugation on coated Fe<sub>3</sub>O<sub>4</sub> nanoparticles (NPs) were investigated. We selectively modified cRGDFK for the targeting of  $\alpha_v\beta_3$  integrins,<sup>1</sup> Erlotinib for the targeting of EGFR<sup>2</sup> and an inhibitor of FAP- $\alpha$  for further conjugation to

NPs through a click reaction. A proof-of-concept for the specific targeting of human cancer cells with Fe<sub>3</sub>O<sub>4</sub> NPs conjugated to cRGDFK is presented.

- Schottelius, M.; Laufer, B.; Kessler, H.; Wester, H.-J. *Acc. Chem. Res.* 2009, 42, 969-980.
- Li, T.; Ling, Y. H.; Perez-Soler, R. J. *Thorac. Oncol.* 2008, 3, 643-647.
- Kelly, T. *Drug Resist. Updat.* 2005, 8, 51-58. Lawandi, J.; Gerber-Lemaire, S.; Juillerat-
- Jeanneret, L.; Moitessier, N. *J. Med. Chem.* 2010, 53, 3423-3.

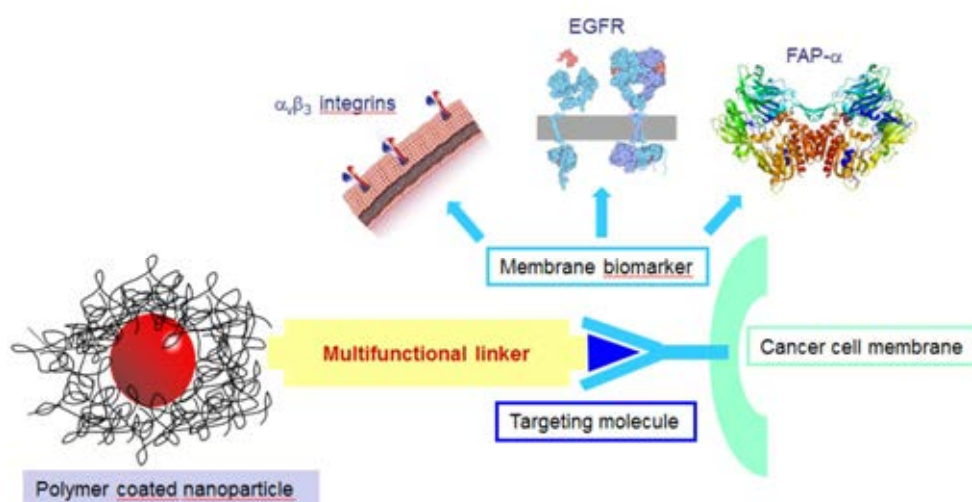

Scheme 1: Multifunctional nanoprobes for cancer diagnosis and imaging



## Detection of magnetic nanowires using Yoke-shaped MgO-barrier magnetic tunnel junction (TMR) and GMR sensors: Towards a magnetic cytometer

N. Carroll, J.Y. Chen, J.M.D. Coey; Magnetism & Spintronics group, School of Physics, Trinity College Dublin. Ireland.

We are interested in developing technologies for the detection of single and segmented magnetic nanowires using yoke-shaped GMR sensors or TMR MgO-barrier magnetic tunnel junction sensors integrated into a microfluidic channel. Towards a magnetic cytometer, we can detect and distinguish single segment nanowires and a two segment nanowire signatures by detecting the stray field of the magnetic nanowires as they pass over the sensor. Also we can detect the number of nanowires passing across the sensor, their velocity and magnetization while moving with velocities of 2–8 mm/s within a microfluidic channel.

Due to constraints and costs associated with flow cytometry there has been a focus in utilizing advances in magnetoresistive sensors, nanowires and microfluidics leading to simpler less expensive instrumentation. These technologies have been integrated into lab-on-chip platforms used for biomolecular recognition and detection.

To achieve this goal we first produced single-metal (Co) nanowires with different wire lengths, which can act as single-metal tags for applications such cell manipulation, separation and labelling. This led to the production of two-segmented wires using CoFe with a copper (Cu) spacer layer (CoFe-Cu-CoFe) which can act as barcodes for detection of disease biomarker molecules. For the detection of the nano-wire stray field a yoke shape GMR spin-valve sensor with a layer sequence of Ta 5/NiFe 3/CoFe 5/Cu 2.8/CoFe 3.5/IrMn 10/Ta 5 (thicknesses in nanometers) was fabricated by sputter deposition and UV lithography processes which provide a good linear GMR response of 7.3%, with a sensitivity of 0.8%/mT and a noise level 13.5 @10Hz. The sensor was deposited and

patterned on a glass substrate to facilitate optical analysis of the nanowires. Subsequently we patterned a yoke-shaped TMR sensor based on an MgO barrier magnetic tunnel junction as an alternate sensor option. The TMR sensors based on a layer sequence Ta 5/Ru 30/Ta5/NiFe 5/IrMn 10/CoFe 2.5/Ru 0.9/CoFeB 3/MgO 2/CoFeB 3/Ta 5/Ru 5 (thicknesses in nanometers) provided a good linear TMR response of 130% with field detectivity about 48 nT/Hz at 1 Hz.

To capture and analyze the signals, a detection system was implemented. This system comprised of an interface for GMR and TMR sensors and a microfluidic chip, low noise preamplifiers and post-amplifiers, current supplies and data acquisition, microscope and camera. Software routines were developed in Labview for data capture and mathcad provided further signal processing for de-noising conditioning of the captured signal response, resulting in improved signal-to-noise ratio and location of actual detected events resulting in an accurate count of the nanowires detected. A number of experiments were carried out to detect nanowires of different wire types, diameters and lengths. Providing data on the number of events of nanowires passing across the sensor, the velocity and magnetization, and a distinction between a single-segmented nanowire and two-segment nanowires.

The resulting prototype system will lead to multiplexed detection of molecular biomarkers of human diseases in a high-sensitivity and throughput format using magnetic nanowire barcodes and is expected to have a number of advantages over existing methods such as flow cytometry.

## Homogenous bioassay based on specifically labeled magnetic nanoparticles in a rotating magnetic field

J. Dieckhoff, M. Schilling, F. Ludwig; Institute of Electrical Measurement and Fundamental Electrical Engineering, Technical University Braunschweig, Braunschweig, Germany.

A homogeneous bioassay enables the wash-free detection of biomolecules in biological suspensions, thus a simple and fast treatment for analyzing biomedical problems is achievable. A promising concept for such a bioassay is based on the magnetic manipulation of specifically labeled magnetic nanoparticles (MNP) in a rotating magnetic field. Here, the measurement of the phase lag  $\phi$  between the rotating magnetic field and the direction of the particles magnetic moment allows the determination of the particles dynamics and finally the analysis of the target molecules binding to the functionalized surface (Fig.1). Applying a defined rotating magnetic field and assuming constant solvent conditions, the particles dynamics and phase lag, respectively, are principally affected by their magnetic moment and hydrodynamic size. In the case of binding target molecules, which cause no crosslinking between the MNPs, the particles effective magnetic moments remain constant and the analyzed phase lag depends only on the MNPs hydrodynamic size. To realize the before described scenario, spherical 30 nm iron oxide nanoparticles with a protein G functionalized shell are specifically conjugated to the Fc region of antibodies. The phase lag spectra of a sample series with a constant amount of these MNPs and different concentrations of an IgG antibody are recorded with a fluxgate

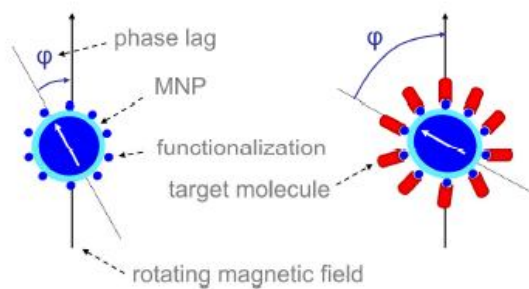

Fig.1: Phase lag change due to target molecule binding.

based measurement setup<sup>1</sup> (markers in Fig. 2). These phase lag measurements clarify that the antibody concentration in the solvent can be well monitored by analyzing the MNPs phase lag in a rotating magnetic field. In addition, the results agree with simulations (lines in Fig. 2), which are based on an empirical equation for describing the MNPs dynamics in a rotating magnetic field<sup>2</sup> and reflect the increase in the MNPs hydrodynamic size, which is related to the relative amount of bound antibodies. The observed phase lag changes enable a usable differentiation between the varying antibody concentrations. A further optimization of the MNPs regarding a stronger magnetic moment and an elimination of possible Néel rotation will cause a higher phase lag change, thus leading to a more sensitive and accurate target molecule detection<sup>3</sup>.

1. J. Dieckhoff, M. Schilling, F. Ludwig, Appl. Phys. Lett., vol. 99, 112501, September 2011
2. T. Yoshida, K. Enpuku, J. Dieckhoff, et al., J. Appl. Phys., vol. 111, 053901, March 2012
3. J. Dieckhoff, T. Yoshida, K. Enpuku, et al., IEEE Trans. Magn., vol 48, no. 11, November 2012

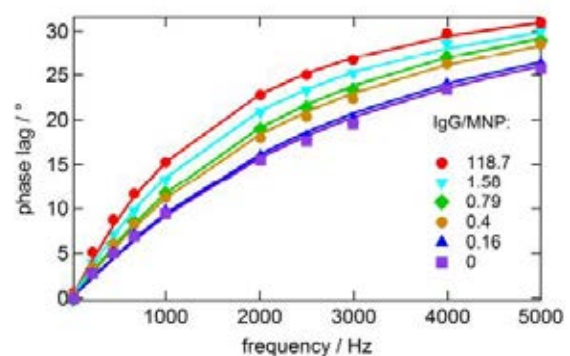

Fig.2: Phase lag spectra of protein G functionalized 30 nm iron oxide nanoparticles with different IgG antibody concentrations.





## Homogeneous biosensor protein detection by monitoring changes in the rotational dynamics of nickel nanorods

S. Schrittwieser<sup>1</sup>, F. Ludwig<sup>2</sup>, J. Dieckhoff<sup>2</sup>, A. Tschöpe<sup>3</sup>, A. Guenther<sup>3</sup>, M. Richter<sup>1</sup>, A. Huetten<sup>4</sup>, H. Brueckl<sup>1</sup> and J. Schotter<sup>1</sup>; (1) Health and Environment Department, Austrian Institute of Technology, Vienna, Austria; (2) Institute of Electrical Measurement and Fundamental Electrical Engineering, Technical University Braunschweig, Braunschweig, Germany; (3) Fachrichtung 7.3 - Technische Physik, Universität des Saarlandes, Saarbrücken, Germany; (4) Department of Physics, Bielefeld University, Bielefeld, Germany.

We present experiments that demonstrate the feasibility of a recently introduced homogeneous immunodiagnostic approach to directly detect analyte binding by optical observation of the hydrodynamic properties of magnetically rotated nanorods ("PlasMag")<sup>1</sup>. Specifically, we show that the phase lag of the long axis of nickel nanorods (magnetic core parameters: length 182 nm, diameter 26 nm) with respect to externally applied rotating magnetic fields significantly increases on the adhesion of bovine serum albumin (BSA) protein to their surfaces. By fitting our measurement results using the theoretical model of Yoshida *et al.*<sup>2</sup>, we obtain a large increase of the hydrodynamic shell thickness of the nanorods by 22 nm, which is related to both the size of the adsorbed protein molecules as well as changes in the stagnant surface layer of immobile fluid. To validate these results, we independently determine the amount of bound protein molecules by analysis of the electrophoretic mobility of

the nanorods, which gives a protein surface density of 5.8 femtomol / mm<sup>2</sup>.

The measured binding of protein to the nanorods is an important first step for realizing the innovative PlasMag biosensing principle, which mimics antibody binding to the nanorods as functional layer for specific detection of antigens. Phase spectra of Ni-nanorods with and without addition of protein and relative phase difference for a rotating magnetic field amplitude of 1 mT. The dots represent measured values, while the lines correspond to the calculated fits. The relative phase difference (blue) reaches a maximum value of about 22° at a frequency of 330 Hz.

1. Schrittwieser et al., ACS Nano 6 (2012) 791-801.
2. Yoshida et al., J. Appl. Phys. 111 (2012) 053901.

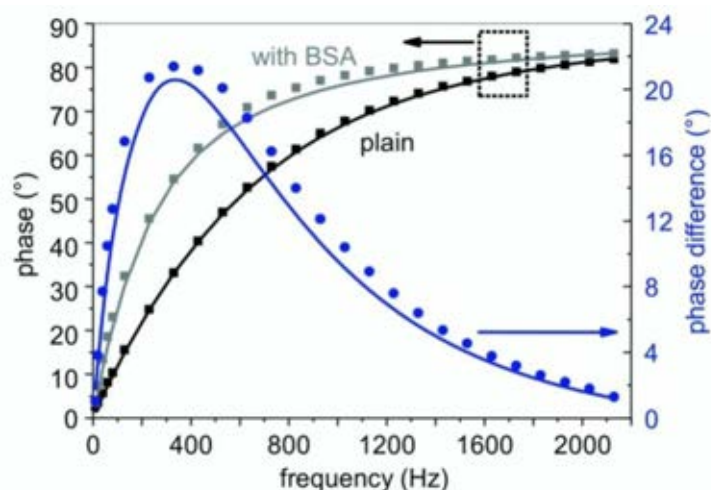

## Developing multiphoton multipurpose characterization system for biomaging materials

A. Rogov, J. Extermann, L. Bonacina, J.-P Wolf; GAP-Biophotonics, Université de Genève, 22 chemin de Pinchat, CH 1211 Genève 4, Switzerland.

Multiphoton excitation offers unique advantages over one-photon excitation for biological and Medical studies. Nowadays one has increasingly become aware of the intriguing possibilities offered by the use of latest probes for multiphoton bioimaging: semiconductor quantum dots QDs<sup>1,2</sup>, harmonic nanoparticles<sup>3</sup>, metal – semiconductor nanohybrids<sup>5</sup> and others. All these materials require deep understanding of their physical properties in order to use them in the most efficient way. This requirement leads to the need for having multipurpose experimental setup able to investigate nonlinear optical properties of nanomaterials. In this work multipurpose experimental setup is presented. The developed setup gives possibility to characterize the nonlinear response of nano-objects in different ways:

1. Record a spectrum of the second harmonic signal or two-photon luminescence.
2. Record 2D/3D scans of the nonlinear response using two-detector configuration: epi-detection and forward-detection.
3. Make the analysis of the polarization response of the sample.

**Description of the setup:** The excitation source is Titanium: Sapphire (Ti:Sa) crystal. In order to compensate for group velocity dispersion in optics, a prism pulse compressor is used. Then the beam is collinearly injected into an inversed laser-scanning microscope. The position of

the sample is controlled by an XYZ piezoscanner. One part of the signal is collected in the transmission direction by an objective. The second part of the signal is epi-collected by the focusing objective used for excitation and separate from the fundamental by a dichroic mirror. A combination of filters assured an efficient rejection of the Ti:Sa excitation scattering. The polarization of the incident light can be linearly modified by a rotating half wave plate (PWP). The polarization of the output beam can be analyzed by a polarization cube. The signal is measured by a photomultiplier tube, amplified by a lock-in amplifier. For spectral measurements, an imaging spectrometer is used. The latter is coupled with an EMCCD camera. Custom developed software allows to couple XYZ movement of a piezo-scanner with a camera and record 2D and 3D spectral images of a sample.

**Further improvements:** As a next step an addition of a high frequency lock-in would strongly improve the sensitivity of the setup and give possibility to work with extremely low intensity signals<sup>5</sup>.

1. M. Albota et al., Science 281, 1653 (1998).
2. D. R. Larson et al., Science 300, 1434 (2003).
3. L. Bonacina, Molecular pharmaceuticals (2012).
4. Y. Zakharko et al., Nanotechnology 24, 5 (2013).
5. W. Min et al., Annu. Rev. Phys. Chem. (2011).

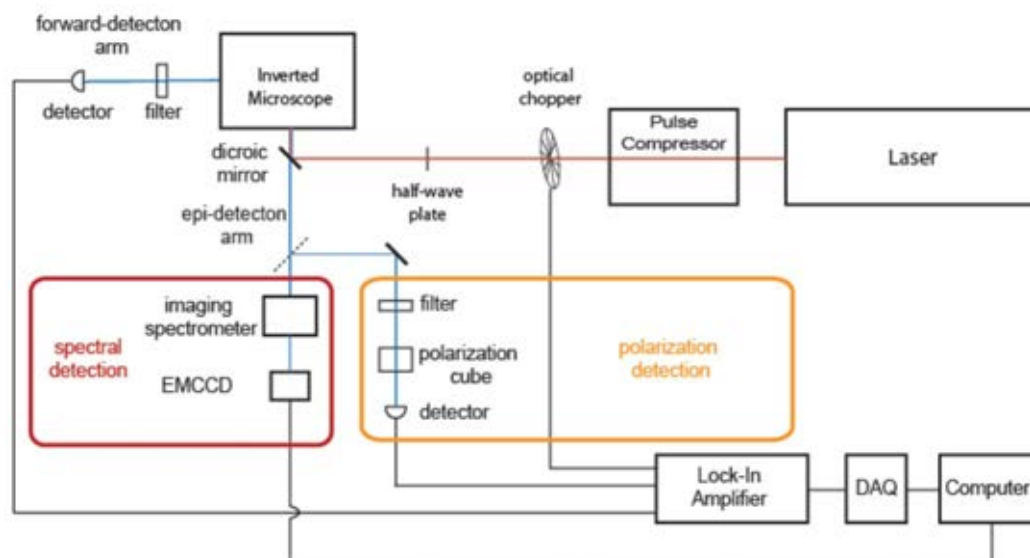



## Nanotechnological Toolkits for the Multimodal Detection and Monitoring of Disease (NAMDIATREAM)

O. K. Mahfoud<sup>1</sup>, T. Rakovich<sup>1</sup>, A. Prina-Mello<sup>1,2</sup>, Y. Volkov<sup>1,2</sup>; (1) Institute of Molecular Medicine, Trinity College Dublin, Ireland; (2) Centre for Research on Adaptive Nanostructure and Nanodevices (CRANN), Trinity College Dublin, Ireland.

Early cancer detection and characterization are accepted as some of the most important factors affecting prognosis, and has a significant impact on the direction of appropriate cancer treatment. Assessment of blood-borne biomarkers has the potential to inform clinicians of the health status of an individual without invasive biopsy and thus show promise for the continuous monitoring of cancer progression. In recent years, nanotechnology has offered some potential solutions towards improving biomarker detection.

By combining immunological sensitivity on a nanomaterial platform with fluidics and sensor development, NAMDIATREAM project partners aim to deliver a test for multiple blood biomarkers, which reduces sample, and time demands. The project incorporates our expanding knowledge of cancer biology and is focused on developing diagnostic biomarker tests for Breast, Lung and Prostate cancer subtypes. Overexpression of human epidermal growth factor receptor 2 (ErbB2), for example, is

considered an important marker for various solid cancers, and is associated with elevated metastatic potential and poor prognosis. Additionally, the soluble cleaved form of ErbB2 protein (sErbB2), found in blood, has been shown to be a viable marker for ErbB2-positive tumour diagnosis. ErbB2 has been approved as an effective target for drug treatment of advanced ErbB2-positive cancer. These factors underlie the importance of development of a robust diagnostic test for ErbB2.

The work presented here details the quantification of soluble ErbB2 levels in clinical blood plasma samples using established techniques (ELISA, Western Blot) and the development of a nanoparticle-based flow cytometric assay for the detection of plasma sErbB2 in single analyte systems and ErbB2-doped blood fractions. These results show functionalization of nanowires with anti-ErbB2 antibodies followed by detection of soluble ErbB2 in single analyte systems using the functionalised nanoprob.

## Application of novel diagnostic nanoprob for immunolabelling of breast and lung cancer biomarkers

T. Rakovich<sup>1</sup>, O. K. Mahfoud<sup>1</sup>, B. M. Mohamed<sup>1</sup>, A. Prina-Mello<sup>1,2</sup>, Y. Volkov<sup>1,2</sup>; (1) Institute of Molecular Medicine, Trinity College Dublin, Ireland; (2) Centre for Research on Adaptive Nanostructure and Nanodevices (CRANN), Trinity College Dublin, Ireland.

In recent years, increased demand for improvement in the area of cancer biomarker detection, with higher specificity and sensitivity and with fewer limitations to those found in fluorescent dyes, has led to an enhanced research into development of new imaging probes. The main focus of this study, funded by EU FP7 large scale integrating project NAMDIATREAM, is the development of nanotechnology for early detection and imaging of molecular biomarkers of the most common cancer types, as well as for a lower threshold identification of the onset of early-stage malignancies. The application of novel multifunctional nanoparticle probes, based on semiconductor quantum dots (QDs), for specific detection and imaging of HER2 receptor in lung and breast cancer cell lines has been demonstrated. Specific targeting of HER2

cell surface receptor with llama-derived single domain (sd) anti-HER2 antibody conjugated with QDs (anti-HER2 QDs) has been examined in breast and lung cancer cell lines and the efficiency of staining has been compared to that of monoclonal anti-HER2 antibody conjugated with Alexa Fluor 488 fluorophore. The properties of these novel sd anti-HER2 QDs imaging probes were examined and compared to that of commonly used monoclonal Alexa Fluor 488 anti-HER2 antibody. It was shown that sd anti-HER2 QDs achieved better imaging resolution in low HER2 protein expressing cell lines. These results raise new possibilities for development of a more sensitive technique for detection and imaging of cancer biomarkers.

## Substrate optimization of a nanostructured plasmonic transfection device

S.D. Courvoisier<sup>1,2</sup>, J. Chen<sup>1,3</sup>, L. Bonacina<sup>2</sup>, J.P. Wolf<sup>2</sup>, E. Mazur<sup>1</sup>; (1) School of Engineering and Applied Sciences, Harvard University, Cambridge, MA, USA; (2) Group of Applied Physics, University of Geneva, Geneva, Switzerland; (3) School of Science, Nanjing University of Science and Technology, Nanjing, China.

The efficient and safe introduction of genetic vectors into mammalian cells is the first step to develop novel approaches for gene therapy, regenerative medicine, and more generally to modify gene expression. Our research aims to develop a very efficient, low toxicity, spatially selective and high throughput transfection method. This method uses plasmonics to focus electromagnetic energy in small volumes and porate cell membranes. A femto-second laser excites surface plasmon modes at the metal-dielectric patterned interface to create highly localized electric field enhancement called "hot spots". The membrane (phospholipid bilayer) of a cell close enough to a hot spot experiences a local electric field greater than the original incident optical field. Beyond a certain threshold, chemical or thermodynamic perturbation of the membrane results in a localized disruption of the cell membrane. The resulting poration of the plasma barrier allows a subsequent influx of charged molecules like naked DNA via diffusion. In this research, we focus our attention on the design of the plasmonic substrate to maximize the electric field enhancement and the focusing at the cell/substrate contact area. Three additional constraints for the design are as follows: 1) a high substrate biocompatibility is required, 2) the hot spot should be projected close to the cell membrane and 3) the substrate should avoid obstruction of the porated area to maximize influx of material.

First, we compare arrays of nanoscale pyramids and of tipless pyramids by simulating the propagation of the Electro-Magnetic fields in three-dimensional substrates by Finite-Difference Time-Domain methods (FDTD). Second, we explore the tipless pyramids geometrical parameters to find the best enhancement/focusing candidates. Third, we fabricated these thin gold tipless pyramids using a template stripping method to compare near-field optical microscopy measurements with the FDTD simulations. This preliminary work will pave the way of future transfection experiments.

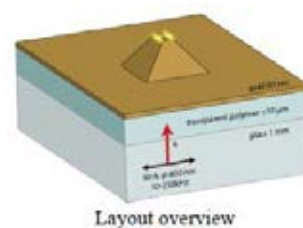

Layout overview

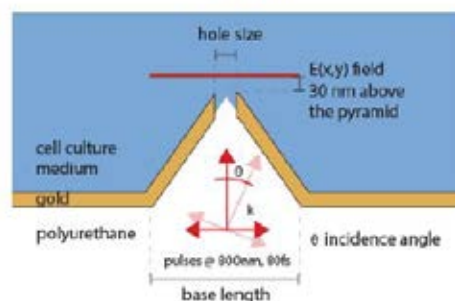

simulation layout cross-section

Fig. 1: Schematics of simulation layout.

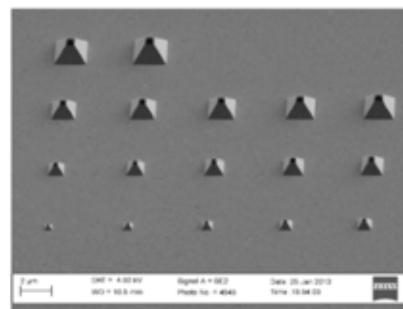

Fig. 2: SEM image: View angle of 45°, thin gold layer tipless pyramids, base lengths from 0.5 to 2.1 µm. Aperture sizes from 125 to 510 nm.



## Immunoassays development for the quantification of cancer biomarkers

M. Uribarri, I. Hormaeche, A. Ametzazurra, D. Fernandez, S. Escorza; Progenika Biopharma, Bizkaia Technology Park, Spain.

EU FP7 funded NAMDIATREAM project will develop cutting edge nanotechnology-based platforms with applications in cancer diagnosis, based on quantifications of selected protein biomarkers with new nanotools. The project is built on the innovative concepts of super-sensitive and highly specific “lab-on-a-bead”, “lab-on-a-chip”, and “lab-on-a-wire” nano-devices utilizing photoluminescent, plasmonic, magnetic and non-linear optical properties of nanomaterials. This approach will offer ground-breaking advantages over present technologies in terms of stability, sensitivity, time of analysis, probe multiplexing, assay miniaturization and reproducibility.

Progenika Biopharma is a biotechnology SME dedicated to personalized medicine, through the development of diagnostic tests for complex diseases. One of Progenika’s main tasks in NAMDIATREAM, focuses on providing all the biological components required for developing the nanotechnology-based tools for the diagnosis of lung, breast and prostate cancers. Several screening processes identified antibody pairs for the measurement of up to 9 protein biomarkers, which were then optimized to generate sensitive, specific and reproduc-

ible sandwich-type immunoassays. Protein biomarker measurement was properly adjusted in the corresponding body-fluid: lung cancer markers in bronchoalveolar lavage, prostate cancer markers in urine and breast cancer markers in serum. These immunoassays will be implemented in the nano-tools by functionalizing nanomaterials with the selected antibodies.

In addition, Luminex® xMAP® technology, one of the most reliable, reproducible and widely used platform for multiplexing detection, was used to develop up to three multiplexed assays: 3-plex for lung cancer markers, 3-plex for prostate cancer markers and 3-plex for CEA-CAM5, EGFR and EpCAM general cancer markers. These assays will be used at later stages to conduct a comparison with the nano-tools assays, which will allow the evaluation of the performance and competitiveness of these newly developed nano-tools in a real clinical setting.

In conclusion, Progenika has generated all the biological components required for developing the nanotools for the diagnosis of lung, breast and prostate cancer diseases.

## Kv10.1 overexpression results in cell-cell adhesion deficits and increased cell motility

I. Alexopoulos<sup>1</sup>, A. Sánchez<sup>2</sup>, S. Klöppner<sup>2</sup>, L. A. Pardo<sup>2</sup>, W. Stühmer<sup>2</sup>, M. Mitkovski<sup>1</sup>; (1) Light Microscopy Facility and (2) Molecular Biology of Neuronal Signals Department at the Max Planck Institute of Experimental Medicine, Göttingen, Germany.

A characteristic of the Kv10.1 voltage-gated potassium ion channel is its overexpression in a number of cancerous tissues and cancer cell lines, even though it should normally be restricted to the adult brain and myoblasts. This compelled us to investigate the role this ion channel may play in cancer, where we initially localized it to filopodia and focal adhesions, both of which are central to cell migration. Therefore, to further study the effect Kv10.1 may have on cell motility, we then generated two HT-1080 cell lines overexpressing either Kv10.1-mVenus or mVenus, both of which were then subjected to a series of scratch assays. Semi-automated, live-cell microscopy and image analysis revealed that Kv10.1 cells tend to close the scratch-induced, cell-free gap more

quickly. While continuous cell-cell adhesion in mVenus overexpressing HT-1080 cells resulted in the typical, coordinated, closed cell migration front, their Kv10.1 overexpressing counterparts migrated in a less coordinated manner evidenced by their cell-cell loss early on in the scratch assay experiment. Individual cell tracking revealed that Kv10.1 overexpression enabled HT-1080 cells to migrate at a faster maximum speed, albeit in a less directional fashion, and thereby accumulate a larger distance, given the same time span. Therefore, the hallmark of increased cell migration in cancer may rely on the abnormal Kv10.1 expression, the understanding of which may yield new diagnostic and treatment targets.

## Validation of tumour-specific fluorescent nanoprobe in a metastatic mouse breast tumour model

J. Bode<sup>1</sup>, J.E. Mathejczyk<sup>1</sup>, F. Ramos-Gomes<sup>1</sup>, W. Stuehmer<sup>1</sup>, L. Pardo<sup>2</sup>, A.K. Wege<sup>3</sup>, T. Rakovich<sup>4</sup>, Y. Volkov<sup>4</sup>, A. Prina-Mello<sup>4</sup>, P. Chames<sup>5</sup>, D. Baty<sup>5</sup>, A. Sukhanova<sup>4,6</sup>, I. Nabiev<sup>4,6</sup>, F. Alves<sup>1,7</sup>; (1) Max Planck Institute for Experimental Medicine, Department of Molecular Biology of Neuronal Signals; (2) Oncophysiology group, Göttingen, Germany; (3) Clinic of Gynecology and Obstetrics, Caritas Hospital St. Josef, University of Regensburg, Germany; (4) Institute of Molecular Medicine, Trinity College Dublin, Dublin, Ireland; (5)INSERM Centre de Recherche en Cancérologie de Marseille, Inserm UMR 1068, CNRS UMR 7258, 13288 Marseille Cedex 09, France; (6) Laboratory of Nano-Bioengineering, Moscow Engineering Physics Institute, 115409 Moscow, Russian Federation; (7) Department of Hematology and Oncology, University Medical Center, Göttingen, Germany.

As a partner of NAMDIATREAM the MPG analyzes *ex vivo* the specificity and sensitivity of fluorescent quantum dots (QDs) conjugated to tumour specific single chain antibodies to detect disseminated tumour cells in biological samples of a human metastatic breast cancer mouse model. Implantation of HER-2 positive SKBR3 breast cancer cells into the liver of neonatal immunodeficient NOD.Cg-Prkdcscid Il2rgtm1Wjl/SzJ mice (JAX®) that were irradiated with 1 Gy for 3 hours before transplantation resulted in a metastatic spread of tumour cells in different organs after several weeks. We applied highly fluorescent quantum dots conjugated to single domain antibodies targeting human epidermal growth factor receptor 2 (HER2-QDs) for detection of cancer cells in biological samples obtained from the metastatic mouse breast tumour model. HER2 positive cells were identified in

primary tumours, and additionally disseminated tumour cells were detected in different organs including brain, testis, lung and intestines with high specificity and sensitivity. Our results show that HER2-QDs were highly specific and sensitive in detecting disseminated tumour cells in mouse tissue. Especially, tumour cells within brain metastasis were specifically stained with HER2-QDs and therefore, in comparison to the use of a commercially available HER2 antibody (Santa Cruz), more easily to detect. In summary, we show the use of specific nanoprobe targeting HER2 positive tumour cells for the identification of disseminated tumour cells in mice. Thus, this nanoprobe-based technology may become a powerful tool to detect tumour cells in biological samples and thereby help to diagnose early cancer or cancer progression by assessing the metastatic spread.

## New theranostic application of second harmonic BFO nanoparticles as phototherapy tool

D. Staedler<sup>1</sup>, T. Magouroux<sup>2</sup>, S. Passemard<sup>1</sup>, G. Stéphane Schneider<sup>1</sup>, S. Schwung<sup>3</sup>, S. Gerber-Lemaire<sup>1</sup>, L. Bonacina<sup>2</sup> and J.P. Wolf<sup>2</sup>; (1) Institute of Chemical Sciences and Engineering, EPFL, LSPN, Batochime, CH-1015 Lausanne, Switzerland; (2) GAP-Biophotonics, Université de Genève, 22 Chemin de Pinchat, CH-1211 Genève 4, Switzerland; (3) FEE GmbH, Struthstrasse 2, 55743 Idar-Oberstein, Germany

The exploitation of optical properties of nanoparticles for therapeutic applications has been recently addressed from different perspectives, the most promising being the application of plasmonic nanoparticles for photothermal therapy and the use of up-conversion nanoparticles as optical transducers in photodynamic therapy [1,2]. However, the capacity of these NPs of doubling the incoming frequency has not been yet directly employed for therapeutic use [2]. Here we propose and validate a new nano-theranostics protocol based on the nonlinear optical process of second-harmonic generation by biocompatible harmonic NPs (HNPs) for the generation of in situ deep UV radiation (270 nm) in human-derived lung cancer cells. Upon treatment with Bismuth Ferrite (BiFeO<sub>3</sub>, BFO) HNPs and pulsed laser irradiation in the visible

spectral region, at 540 nm, we observed and quantified the appearance of double-strand breaks (DSBs) on DNA and apoptosis, exclusively localized in the area of laser beam. We showed that DNA-damages are dependent on irradiation-time, laser intensity, and HNP concentration. Moreover, with this approach independent access to imaging and therapeutic modalities was possible by simply tuning the excitation wavelength. In summary, this study opens new modalities for theranostics applications and photodynamic therapy based on HNPs.

1. Huang, X. et al. *Lasers Med Sci* 2008.
2. Bonacina, L. *Mol Pharm* 2012.



## Bioimaging with rationally designed NIR-fluorescent nanosensors

T. Behnke<sup>1</sup>, J. E. Mathejczyk<sup>2</sup>, J. Napp<sup>2</sup>, K. Hoffmann<sup>1</sup>, C. Würth<sup>1</sup>, F. Alves<sup>2</sup>, M. Schäferling<sup>3</sup>, U. Resch-Genger<sup>1</sup>; (1) BAM Federal Institute for Material Research and Testing, D-12489 Berlin, Germany; (2) Department of Hematology and Oncology, University Medical Center Göttingen, and Department of Molecular Biology of Neuronal Signals, Max-Planck-Institute for Experimental Medicine, Göttingen, Germany; (3) Institute of Analytical Chemistry, Chemo- and Biosensors, University of Regensburg, D-93040 Regensburg, Germany.

Fluorescence-based techniques are amongst the most widespread tools in the material and life sciences, with new applications continuously emerging. Current trends include signal amplification strategies as well as multiplexing strategies to increase the overall detection sensitivity and to enable the simultaneous detection of several analytes or species. This can elegantly be achieved with fluorescent particles loaded with a single or with mixtures of dyes. Particles stained with chromophores emitting in the near-infrared (NIR) spectral region allow the fluorescence detection within the diagnostic window between ca. 650 to 950 nm. For the majority of *in vitro* or *in vivo* applications, detection within this region is mandatory especially for deep tissue imaging, to minimize scattering and absorption from water, tissue, and blood components and signal contributions from their autofluorescence. Furthermore fluorophore incorporation in micro- and nanoparticles (NPs) can reduce unspecific interactions between the dye molecules and the surrounding medium and can minimize cytotoxic effects. Moreover, the encapsulation of NIR emitting dyes can enhance their photochemical and thermal stability as well as their usually low fluorescence quantum yields in polar and protic solvents like water. Accordingly, straightforward and versatile methods for the staining of polymeric NPs were developed by us resulting in highly emissive and stable particles. Different surface functionalities of these nanoscale fluorescent reporters can be easily bio-functionalized to yield targeted probes and sensors. Here, we present the preparation and characterization of bright, NIR-fluorescent polystyrene NPs using our one-step staining procedure, which can be easily adapted to various dye classes<sup>1</sup>. We further demonstrate the potential of the resulting particles in different applications, i.e. for biomarker targeting, spatial or time resolved cellular imaging, and as lifetime multiplexing platform. For the application as targeted optical NIR-probe for cancer diagnostics we modified the surface of our

emissive NPs with the monoclonal antibody Herceptin. These particles, stained with our novel, bright NIR-dye Itrybe with broad absorption and emission bands and a large Stokes-shift show the feasibility of this system for *in vivo* imaging<sup>2</sup>. Particles doped with an oxygen-sensitive and an inert dye yield a targeted ratiometric nanosensor for oxygen for the monitoring of pathophysiological changes *in vivo*<sup>3</sup>. To show the suitability of this system as platform or label for lifetime multiplexing detection schemes in cellular imaging we incubated two cell lines (3T3 fibroblasts and J774 macrophages) with mixtures of differently stained and sized NPs. Here, the resulting different fluorescence lifetime decays were exploited to distinguish uptake behaviour, cells or compartments<sup>4</sup>.

1. Behnke, T.; Würth, C.; Laux, E.-M.; Hoffmann, K.; Resch-Genger, U.: „Simple Strategies Towards Bright Polymer Particles via One-step Staining Procedures”, *Dyes Pigments* 2012, 94, 247-257.
2. Behnke, T.; Mathejczyk, J.E.; Brehm, R.; Würth, C.; Ramos Gomes, F.; Dullin, C.; Napp, J.; Alves F.; Resch-Genger, U.: “Target-specific Nanoparticles Containing a Novel Broad Band Emissive NIR Dye for *in vitro* and *in vivo* Imaging”, *Biomaterials*, 2013, 34, 160-170.
3. Napp, J.; Behnke, T.; Fischer, L.; Würth, C.; Wottawa, M.; Katschinski, D. M.; Alves, F.; Resch-Genger, U.; Schäferling, M.: “Targeted Luminescent NIR Polymer-Nanoprobes for *In Vivo* Imaging of Tumour Hypoxia”, *Anal. Chem.* 2011, 83, 9039-9046.
4. Hoffmann, K.; Behnke, T.; Drescher, D.; Kneipp, J.; Resch-Genger, U.: “Lifetime-based Discrimination between Spectrally Matching vis and NIR Emitting Particle Labels and Probes”, *Proc. SPIE* 2011, 7905, 79051F; doi: 10.1117/12.881442.

## High-Speed Tracking of Murine Cardiac Stem Cells by Harmonic Nanodoublers

T. Magouroux, J. Extermann, P. Hoffmann, Y. Mugnier, R. Le Dantec, M. E. Jaconi, C. Kasparian, D. Ciepielewski, L. Bonacina, and J.P. Wolf; GAP-Biophotonics, Université de Genève, 22 chemin de Pinchat, CH 1211 Genève 4, Switzerland.

In patients who survive heart attacks, dead heart cells are replaced by fibroblasts, which form scar tissue that no longer contracts properly. Like many specialized cells, fully developed heart cells do not divide and so are unable to patch up damage. Cardiac stem cells are thus a potential source of cells for cardiac transplantation therapy.

However, a complete understanding of the integration mechanism of stem cells or derivatives into a native tissue after transplantation is still missing. This lack of knowledge descends primarily from the difficulty to track in a continuous fashion and for extended time periods (days to weeks) transplanted cells within tissues at sub-cellular spatial resolution.

In this work, we present an innovative labelling approach for embryonic stem cells (ESC), based on harmonic nanoparticles (HNPs). The latter are inherently nonlinear labels that can fully exploit the potential of multiphoton imaging, featuring complete absence of bleaching and blinking, excitation-wavelength tunability, narrow emission bands, orientation retrieval capability, and coherent optical response. The two former properties are amenable for employing them for long term tracking of stem cells embedded in tissues. In particular, wavelength tunability allows using infrared light for excitation,

increasing penetration and minimizing sample photo-degradation and autofluorescence.

We show that potassium niobate (KNbO<sub>3</sub>) HNPs stabilized by polyethylene glycol (PEG) efficiently bind to differentiating ESC membranes without interfering with their development and differentiation. In particular, we show for the first time that the strong second harmonic (SH) signal emitted by individual HNPs can be used for monitoring at high acquisition speed the rhythmic contractions of ESC-derived cardiomyocytes beating within a 3D cluster. The 3D contraction pattern obtained by this approach is analysed to extract information at the cellular level. The approach proposed here can be readily applied to monitor the evolution of various stem cell types in a transplanted tissue or their integration in a 3D supporting structure.

1. T. Magouroux, J. Extermann, P. Hoffmann, Y. Mugnier, R. Le Dantec, M. E. Jaconi, C. Kasparian, D. Ciepielewski, L. Bonacina, and J. P. Wolf, "High-Speed Tracking of Murine Cardiac Stem Cells by Harmonic Nanodoublers," *Small* 8, 2752-2756 (2012).
2. C. L. Mummery, "Cardiology: Solace for the broken-hearted? (vol 433, pg 585, 2005)," *Nature* 434, 35-35 (2005).

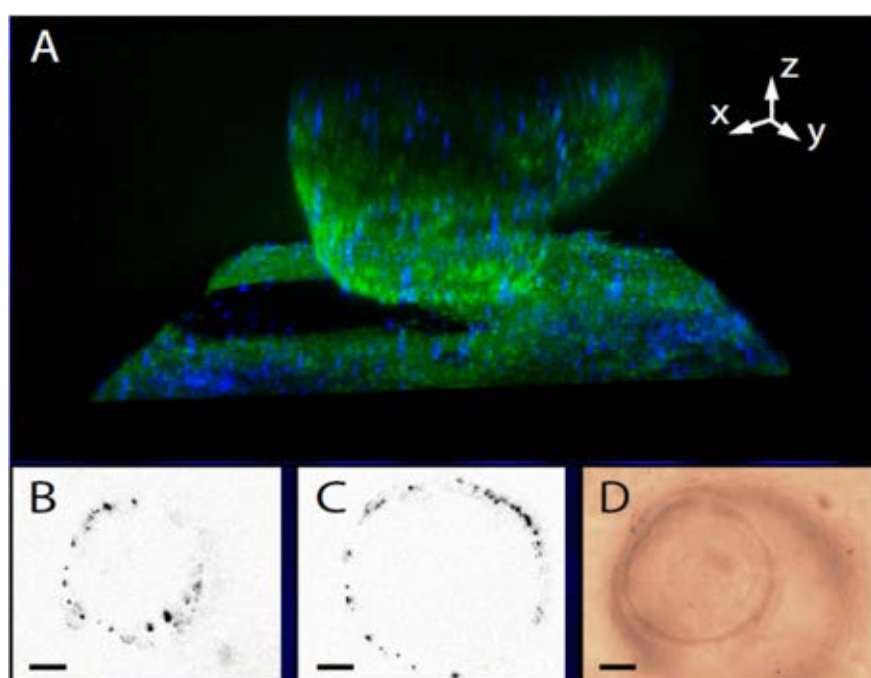

Fig. 1: (A) Differentiating 3D EB labeled with HNPs (green: cells autofluorescence, blue: SH signal from HNPs). Scan size:  $640 \times 640 \times 330 \mu\text{m}$ . (B) and (C) Horizontal sections of the SH channel at two different heights (B =  $92 \mu\text{m}$  and C =  $220 \mu\text{m}$ ). (D) Brightfield image of the same structure. Scale bar:  $50 \mu\text{m}$ .





## Nanotoxicology screening of coated iron oxide nanoparticles: for the selection of lead candidate for theranostic applications

K. Crosbie-Staunton<sup>1,\*</sup>, A. Prina-Mello<sup>1,2,\*</sup>, O. L. Gobbo<sup>3</sup>, G. Salas<sup>4,5</sup>, M. del Puerto Morales<sup>4</sup>, Y. Volkov<sup>1,2</sup>; (1) Trinity Centre for Health Science, St. James's Hospital, Dublin 8, Ireland; (2) Centre for Research on Adaptive Nanostructures and Nanodevices (CRANN), Trinity College Dublin, Ireland; (3) School of Pharmacy and Pharmaceutical Sciences, Trinity College Dublin, Ireland; (4) Instituto de Ciencia de Materiales de Madrid/CSIC, Sor Juana Inés de la Cruz 3, Madrid, Spain; (5) IMDEA Nanociencia, Madrid, Spain. \* These authors contributed equally.

Nanotoxicology and biocompatibility testing of nanoparticles has become a vital task in the development of safe and feasible medical platforms for next generation drug delivery, disease identification, and monitoring. Magnetic iron oxide nanoparticles (MNP) have received considerable attention in recent years with their potential use as magnetic resonance imaging contrast agents, in therapeutics and their added ability to formulate numerous derivatives using a large pool of cancer targeting moieties.

As part of the MULTIFUN FP7 work presented here we focus on the development and validation of high content imaging and analysis for *in vitro* nanotoxicity and biocompatibility testing assays of select-coated MNPs (Aminopropylsilane (ASi), dimercaptosuccinic acid (DMSA/OD10), polyacrylic acid (PAA), dextran (F1566) and aminodextran (ADNH)) with defined iron oxide core sizes and biocompatible coatings.

The physical properties of the coated MNPs were comprehensively characterised by TEM, DLS and NTA. Multiparametric high content screening analysis was carried out to evaluate the toxic effect following exposure with the coated MNP at multiple concentrations in four breast cancer cell lines (MCF7, BT474, MDA231 and SKBR3) and a normal-like breast cell line (MCF10A).

Changes in the total cell count reduction, lysosomal intensity/pH and cell permeability were analysed following 24 h exposure.

In line with *in vitro* studies, further characterization of selected MNPs has been investigated *in vivo* in small animal models. Bio-distribution was studied to determine systemic persistence in small animals using 7T magnetic resonance imaging and the total iron concentration in selected organs (heart, liver, kidney, spleen, lungs and brain) was determined using the pulsed electron paramagnetic resonance technique.

Thus by adopting a systematic high content screening approach using comprehensively characterised MNPs of similar and defined core size, in testing their nanotoxicity, it is possible to quantitatively gain distinguishing differences between the behaviour of their surface response to cellular models in terms of uptake, time-dependent and dose interaction. This work demonstrates that through consideration of the MNP physico-chemical properties and multiparametric toxicity analysis of clearly defined endpoints on clearly identified *in vitro* cell models in parallel with *in vivo* studies, the identification of a biocompatible nanoparticle can be achieved prior to the development of additional structural complexities.

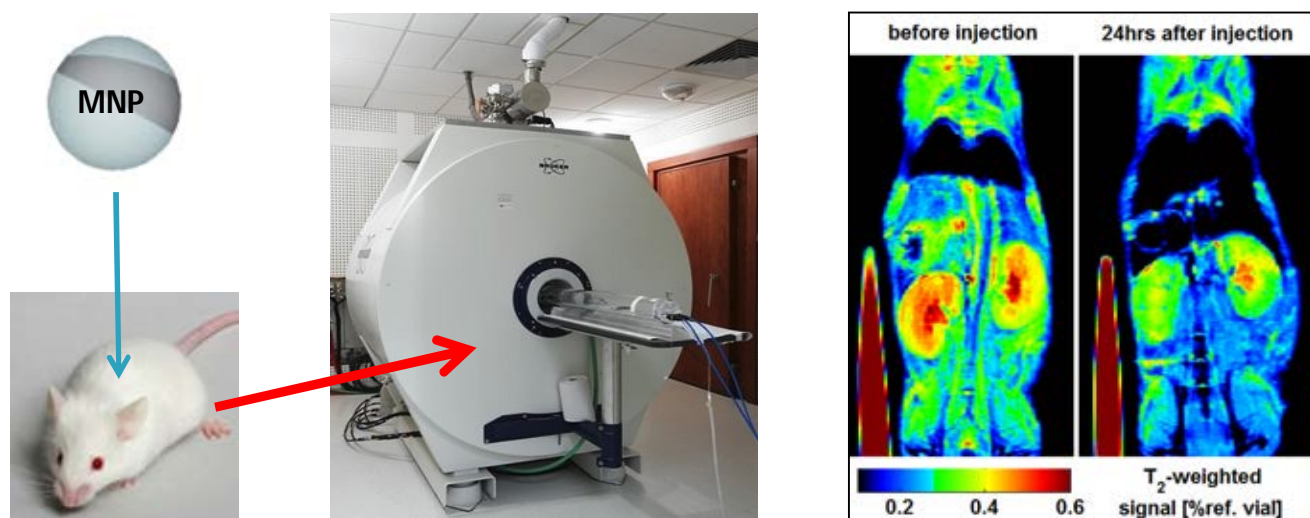

## Imaging techniques for pancreatic ductal adenocarcinoma (PDAC) diagnostics based on Eag1 voltage gated potassium channel

M. Saccomano<sup>1</sup>, C. Dullin<sup>2</sup>, F. Hartung<sup>1</sup>, A. Schwab<sup>3</sup>, W. Stühmer<sup>1</sup>, L.A. Pardo<sup>1</sup>, F. Alves F<sup>1,4</sup>, J. Napp J<sup>1,2,4</sup>; (1) Max-Planck-Institute for Experimental Medicine, Goettingen, Germany; (2) Department of Diagnostic Radiology, University Medicine Göttingen, Georg-August-University, Goettingen, Germany; (3) Institute of Physiology II, Universitätsklinikum Münster, Münster, Germany; (4) Department of Hematology and Oncology, University Medicine Göttingen, Georg-August-University, Goettingen, Germany.

Pancreatic ductal adenocarcinoma (PDAC) has one of the worst prognoses of all cancers. The failure to improve the disease outcome can be largely attributed to a lack of specific therapies, pointing to the need for identification of novel targets for the therapeutic intervention in order to combat this widespread disease. A growing body of evidence indicates that ion channels, transporters and associated proteins (the "transportome") are expressed aberrantly in cancer and may represent promising novel targets for clinical interventions. The aim of the IonTraC consortium (<http://www.iontrac.uni-muenster.de>) is to develop therapeutic and diagnostic concepts and tools that are based on transport proteins serving as novel drug targets and/or biomarkers in pancreatic cancer. One of the promising molecular targets for novel cancer therapies is the Eag1 voltage gated potassium channel. Besides the central nervous system Eag1 is aberrantly expressed (>75%) in tumours from diverse origin and, as expressed in the cell membrane, it is easily accessible to extracellular interventions. A time-domain near infrared fluorescence (NIRF) imager was applied to study in vivo

binding and biodistribution of Cy5.5 labeled anti-Eag1 antibody, mAb62-Cy5.5, in a subcutaneous MDA-MB-435S tumour model in nude mice over time. The mAb62-Cy5.5 specifically binds to the tumour for at least 1 week in vivo with maximum intensity peak at 48 h. Blocking experiments with an excess of unlabelled mAb62, as well as application of the free Cy5.5 fluorophore confirmed the binding specificity. Ex vivo NIRF imaging of whole tumours, as well as NIRF imaging and -microscopy of tumour slices confirmed accumulation of the mAb62- Cy5.5 in tumours, but not in brain tissue. In summary, the anti-Eag1 antibody represents a very promising tool for development of novel diagnostic strategies in PDAC. Consequently, other members of the transportome, which play a role in the development and progression of PDAC, will be identified within the framework of the IonTraC consortium. The future aim of this project is to develop and evaluate preclinically novel imaging probes including antibodies, peptides or small molecules targeting members of the transportome as diagnostic tools in PDAC.

# Workshops at Euronano Forum 2013

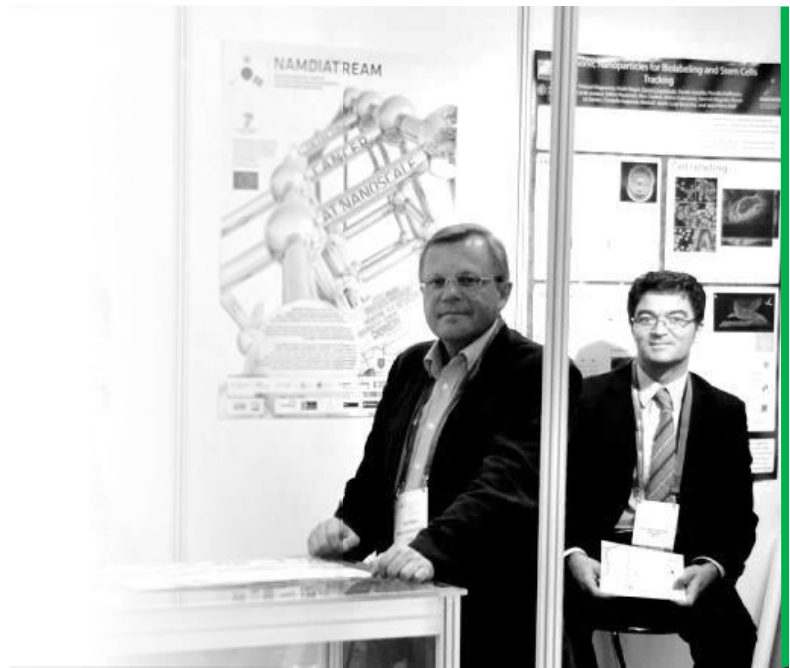

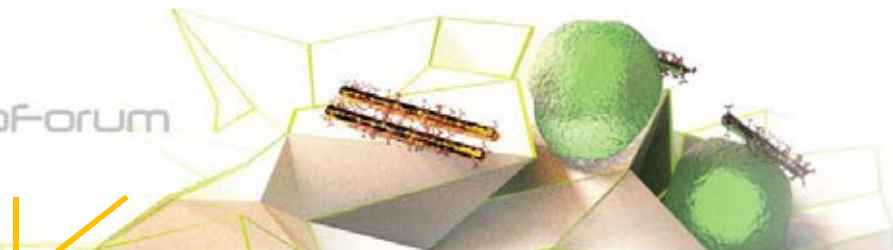

## Overview of Conference and Workshops

At the 2013 EuroNanoForum (ENF) conference, the NAMDIATREAM project made a major contribution to bridging the gap between the world of medical research/innovation and that of the nanotechnology stakeholders, by collaborating to organize two workshops entirely dedicated to the nanomedicine. The ENF was a great opportunity for the nanomedicine community to emphasize to a large panel of research, industry and public authority representatives, the huge potential of nanotechnology as an enabling technology for medical applications. With participation at ENF supported by the European Technology Platform on Nanomedicine (ETP Nanomedicine), the nanomedicine field was widely represented and specific needs and requirements for the successful implementation of nanotechnologies in the health sector were highlighted.

The ENF 2013 conference, organized by Enterprise Ireland, was held in Dublin in June 2013 during the Irish presidency of the European Union under the motto "Nanotechnology Innovation: From research to commercialization, the bridge to Horizon 2020". The event was a tremendous success, attracting nearly 1,500 active members of the nanotechnology community from 50 countries around the world. Over 140 high-level speakers presented at the plenaries, sessions and workshops. Nanotechnology developments and commercialization success stories were also visible at the coinciding Nanotech Europe exhibition. The event was supported by the European Commission and its Industrial Technologies programme, and co-organised by Enterprise Ireland and Spinverse Ltd.

The focus of the conference was the commercialization of nanotechnology, exploiting its potential for new applications, pushing it from an enabling technology through to use in end products. Industrial and research organizations such as BASF, Shell, Ottobock, Nanobiotix, Intel, Philips Healthcare, Airbus, VTT, Fraunhofer, Max-Planck Institute, CRANN, Tyndall, MSSI and NanoStart, initiated a thriving discussion about the future of nanotechnology, its economic and technological impact on

European growth and the commercialization challenges of nanoproducts. Speakers agreed that understanding of industrial needs, focused R&D and suitable funding instruments are required, as is the identification of areas where nanotechnology is most likely to have an impact.

The Nanotech Europe exhibition completed the conference. Here, 70 innovative organizations from 20 countries like Austria, the UK, Germany, Denmark, Finland, France, the Czech Republic, Switzerland and the Netherlands showcased their ground-breaking innovations. In the meantime, a brokerage day on June 20<sup>th</sup> saw 50 parallel meetings take place, sparking new businesses, project consortia and cooperative activities for technology transfer.

With Horizon 2020 beginning in 2014, the conference offered a unique chance to look at how nanotechnology will fit into the new structure's key priority areas of *excellent science*, *industrial leadership* and *societal challenges*. "Today, as demonstrated in ENF 2013, nanotechnology applications can be found in all areas of industrial technologies", commented Dr. Herbert von Bose, Director of the Industrial Technologies Programme of DG Research and Innovation at the European Commission. "Still, a lot more needs to be done, especially in fastening the pace of industrial innovation. We are looking forward to continuing our work within the next seven-year programme of Horizon 2020, following the principles of safe, responsible and sustainable nanotechnology development and ensuring the competitiveness and growth of European industries".

The central role of nanomedicine within the sphere of applied nanotechnology was one of the key topics at the conference; and this point was emphasized by the award for Best Research Project going to the EU nanomedicine project, SONODRUGS. The project aims to develop novel technologies for drug delivery to enable localized treatment of cardiovascular disease and cancer. For patients, this could mean a treatment with fewer side effects and burdens, in addition to reduced post-intervention recovery times.



## Nanomedicine at EuroNanoForum 2013

Nanomedicine research and applications were the focus of two workshops and two of the life science sessions. They received endorsement and direct contributions from ETP Nanomedicine

During the first day, the “Healthcare Session” dealt with technology transfer and commercialization of nanotechnology-based healthcare innovations, focusing on industry needs, with presentations, among others, by Dr. Hans Hofstraat, Vice President of Philips Research, and Dr. Patrick Boisseau, Chair of the ETP Nanomedicine.

The “Session on Advances in Bionanotechnology” was held the second day. Here, nanobiotechnology was shown to provide tools for the study of living matter at the nanoscale, and to generate scientific and technological advances in the fields of medicine and biology. In addition, biomimetic approaches to creating new crystalline nano-materials was illustrated as a further example of bionanotechnology, highlighting its impact beyond the biological sciences.

During the third day, the two nanomedicine-focused workshops took place with the direct involvement of the NAMDIATREAM project, which contributed to defining the workshop’s mission and program. The main objectives were to describe, with the interests of all stakeholders in mind, the current action plan and measures taken to foreground the field of nanomedicine, and to highlight the policy actions, led by the ETP Nanomedicine, to integrate nanomedicine as a horizontal topic in Horizon 2020 (H2020).

Workshop 7, titled, “Nanomedicine: Technology Platforms and Breakthrough Projects”, centred around ongoing EU nanomedicine projects and initiatives, the White Paper contribution of the ETP Nanomedicine to H2020, as well as current actions to support initiatives of transnational multidisciplinary research in nanomedicine by fostering the competitiveness of the European nanomedicine actors.

The clinical translation of nanomedical technologies requires the stakeholders to understand and apply the process of open innovation, which is essential for translation into the clinic. As stated in the ETP Nanomedicine “White Paper”, the best option for successfully implementing the open innovation model in Europe involves establishing a supply chain providing nanomedicine products compatible with industrial processes and strategies. The ETP Nanomedicine has a track record as a neutral communication platform and think tank for academia, SMEs and industry; this has allowed it to foster interaction between key players, leading to translation of scientific inventions into healthcare products. Based on this unique European experience, the ETP Nanomedicine and its FP7-funded projects are working on collaborative platforms that contribute to the development of the associated healthcare-industry organizations and a number of the roadmaps and visions of the European Commission.

The session was chaired by Dr. Patrick Boisseau (ETP Nanomedicine and CEA Grenoble, France) and co-chaired by Dr. Laurent Levy (Nanobiotix, Paris, France) and Dr. Adriele Prina-Mello (Trinity College Dublin, Ireland). The panel of experts was composed of ETP Nanomedicine Executive board members and EC representatives. The sessions were organized by Dr. Adriele Prina-Mello (NAMDIATREAM Deputy Coordinator).

Workshop 8 was titled, “Market Strategies in Medical Device Sector”. The starting point of this workshop was the realization that nanotechnology and nano-materials have majorly contributed to innovation within the medical device industry. This has led to tremendous advances in the provision of care for patients worldwide, but continued progress will require effective innovation solutions taking advantage of the most advanced scientific breakthroughs.

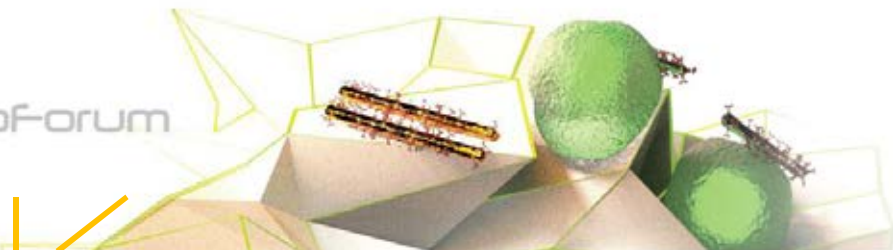

## Presentation Highlights

### Nanomedicine: Technology Platforms and Breakthrough Projects (Workshop 7)

Nanotechnology has already provided several medical solutions for both therapeutics and diagnostics, but progress in clinical translation requires the stakeholders to understand and apply the process of open innovation. As stated in the previous section, establishment of a supply chain of industry-compatible nanomedical products would be an important part of this open innovation model. Such a task would necessitate major changes in the thinking of all stakeholders and the empowering of an organization to actively manage the translation effectiveness of its members (academics and SMEs) to help revitalize industry in Europe.

Key tasks to foster open innovation in nanomedicine, to be put in place by the ETP Nanomedicine, have been identified as the creation of a Translation Advisory Board (TAB) and new infrastructures supporting the translation of nanomedical products into the clinic. The TAB will need to include experienced industrial experts, who will apply horizontal innovation filters to R&D proposals from academics and SMEs to select, guide and push the best translatable concepts towards funding and clinical proof of concept. The new infrastructures supporting the translation of nanomedical materials will include a European Nano-Characterization Laboratory (EU-NCL), a European Pilot line for GMP manufacturing of batches for clinical trials (GMP Pilot Lines); a European network of preclinical centres of excellence; and co-ordination of the efforts of European clinical organizations in nanomedicine. The TAB, together with the new infrastructures and an active support towards the setting-up of a dedicated NanoMed SME instrument will create an umbrella of complementary actions and initiatives within the **Translational Hub**. The four key elements composing the Translation Hub (EU-NCL, GMP Pilot Lines, the SME Instrument and TAB) aim to be the most relevant concepts for ensuring the competitiveness of European Research and Innovation. More details are available on the ENF website where it is possible to download the presentation given by Dr. Patrick Boisseau (CEA, France), chair of ETP Nanomedicine:

<http://www.euronanoforum2013.eu/wp-content/uploads/2013/07/Boisseau-Nanomedicine-Workshop.pdf>

“Small but heading to a big future” is the motto of **Nanobiotix**, but this ambition could be extended to the entire nanomedicine field. Founded in 2003, the company has already established itself as a pioneer in nanomedicine, developing a pipeline of first-in-class products targeting cancer. The first product, NBTXR3, has now achieved a clinical milestone, reaching proof-of-concept in a phase I trial for the treatment of soft tissue sarcoma. Local procedures like surgery and radiotherapy play an important role in the treatment of solid tumours, and they also increase the probability of success for systemic treatments. The innovation in Nanobiotix lies in their NanoXray technology, which comprises three products to selectively increase the efficacy of radiotherapy against tumour cells, promising to overcome some of the limitations of standard radiotherapy. During the workshop, NanoBiotix CEO, Dr. Laurent Levy, described the impressive achievements of this company; more details can be found in the presentation itself:

<http://www.euronanoforum2013.eu/wp-content/uploads/2013/07/L-Levy-Nanomedicine-Workshop.pdf>

The first breakthrough project to be presented at the workshop was **NAMDIATREAM** and this was done by its coordinator Prof. Yuri Volkov (Trinity College Dublin). The NAMDIATREAM project, which targets development of nanotechnological toolkits for multi-modal cancer diagnostics and treatment monitoring, is an excellent example of a strong interdisciplinary effort in nanomedicine. It is a pan-European consortium built around 7 high-tech SMEs, 2 multinational corporations and 13 academic institutions. The breakthrough innova-



tions that NAMDIATREAM brings to medicine centre on the concepts of super-sensitive “lab-on-a-bead”, “lab-on-a-chip” and “lab-on-a-wire” nano-devices, which are tackled from the standpoints of both academic and industrial science. Prof. Volkov’s presentation is available from the ENF website:

<http://www.euronanoforum2013.eu/wp-content/uploads/2013/07/Y-Volkov-Nanomedicine-Workshop.pdf>.

Multifunctional Nanotechnology for selective detection and Treatment of cancer, **MULTIFUN**, is an FP7 large-scale collaborative nanomedicine project. The MULTIFUN consortium focuses on the development and validation of new nanotechnological systems for the early, selective detection and elimination of breast and pancreatic cancer with reduced side effects. The project will deploy a strategy based on the multifunctionalization of magnetic iron oxide nanoparticles (MNPs) to produce a potential “theranostic” tool, combining diagnostic and therapeutic features against cancerous breast, pancreatic and stem cells. To improve the translation of the research outcomes and their economic potential, a major part of the project is focused on studying the scale-up of the production methods for the main components. More information is available from the presentation of Prof. Bonifacio Vega (IMDEA, Spain) at this link:

<http://www.euronanoforum2013.eu/wp-content/uploads/2013/07/B-Vega-Nanomedicine-Workshop.pdf>

**TRANS-INT** is a large-scale collaborative FP7 project devoted to the development of nanocarriers for the transport of therapeutic macromolecules across the intestinal barrier. The administration of medical macromolecules via the oral route will greatly increase patient’s compliance and quality of life, especially for chronic diseases that require daily administration of macromolecular drugs, such as diabetes. Yet the oral administration route poses a big challenge due to the gastrointestinal environment, which degrades most macromolecules. Nanoparticles are able to overcome

this problem by protecting the drug and allowing it transport through the intestinal barrier. The concept behind TRANS-INT is the rational design of oral nanomedicines based on safety, mechanistic, bioengineering and pharmaceutical technology criteria. The consortium is composed of 16 partners from industry and academia with complementary leading expertise in chemistry, chemical engineering, pharmaceutical technology, molecular physiology, biopharmaceutics, toxicology and drug development. Prof. David Brayden (University College Dublin) presented this project as deputy coordinator. Further details can be found at the link below:

<http://www.euronanoforum2013.eu/wp-content/uploads/2013/07/D-Brayden-Nanomedicine-Workshop.pdf>

**ALEXANDER** is another large-scale collaborative FP7 project, with the aim of identifying novel strategies for the efficient transport of nanocarriers through the mucus gel layer (e.g. intestinal, ocular), while also optimizing existing strategies. In particular, R&D activities are focused on the synthesis of functionalized nanocarriers capable of permeating the mucus gel layer and delivering their therapeutic payload to the epithelium. Such nano-delivery systems are expected to open the door to oral versions of currently injected macromolecular drugs, such as insulin and EPO-mimetics. It is hoped that they will also lead to radical improvements in ocular treatments and in non-viral gene therapy in mucosal tissues, e.g. treatment of cystic fibrosis with the CFTR-gene. The interdisciplinary ALEXANDER consortium consists of 14 partners from 8 European countries, with 5 universities, 2 research institutes, 3 large industrial partners and 3 SMEs. More details can be found in the presentation of the coordinator, Prof. Silke Megelski (DECHEMA e.V.) at the following link:

<http://www.euronanoforum2013.eu/wp-content/uploads/2013/07/S-Megelski-Nanomedicine-Workshop.pdf>

The last presentation of this Workshop was dedicated to **EuroNanoMed II** (ENM II), an ERA-NET under the FP7 NMP programme 2012–2016, presented by the

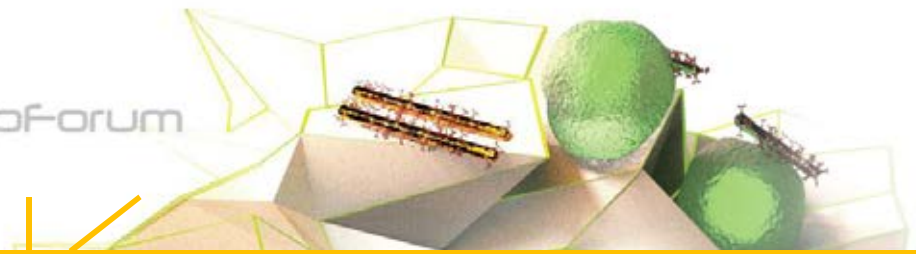

coordinator, Prof. Natalia Martin, of the French National Research agency (ANR). ENM II is based on the foundations of ENM I (ERA-NET under the FP7 NMP programme, 2009–2011), which laid the ground for a transnational research programme that responds to the needs of the nanomedicine community (ENM I strategic agenda, ETP Nanomedicine). ENM II has 20 partners in 17 countries, and its main objectives are to

- develop innovative diagnostic and therapeutic solutions for the patient
- solve unmet medical needs and improve the efficacy of current medical solutions
- contribute to maturation of the nanomedicine field in Europe
- allow multidisciplinary collaboration between the best researchers/teams in nanomedicine, bringing together teams from academic/public research and the clinical/public health industry
- increase the attractiveness of multidisciplinary and transversal nanomedicine research to the younger generation of scientists

- provide a platform dedicated to young scientists' information and networking
- use specific measures to stimulate the participation of young scientists in the ENM II calls

Other objectives of the ENM II are to continue the European coordination of research programmes in nanomedicine, integrating new members, keeping close relations with the relevant stakeholders (especially the ETP Nanomedicine) and the research community in order to react flexibly to needs and new developments in nanomedicine. In addition, ENM II aims to collaborate with other ERA-NETs to create synergies that integrate lessons/solutions learned from others (JTCs, young researchers, sustainability, etc.) and implement common activities (calls, workshops, etc.). Further details of the presentation on ENM II are available at this link:

<http://www.euronanoforum2013.eu/wp-content/uploads/2013/07/N-Martin-Nanomedicine-Workshop.pdf>.





## Market Strategies in the Medical Device Industry (Workshop 8)

Nanomedicine has established a substantial presence in today's markets, with engineered nanomaterials already providing medical enhancements that, otherwise, would not have been achievable. Furthermore, Europe has a competitive medical device industry, producing a great variety of devices and offering patients timely access to innovative products. Nevertheless, a recent analysis on nanomedicine commercialization by Etheridge and colleagues (published in *Nanomedicine: Nanotechnology, Biology, and Medicine* 9 (2013) 1–14) highlighted the infancy of the field, pointing to the fact that a large portion of the nanomedicine applications identified are still in the research and development stage.

The study reveals two clear needs that should be addressed for nanomedicine to succeed: 1) development of a clear and effective of the field and 2) creation of a standardized approach for gathering, sharing and tracking relevant information on nanomedical applications and products, without the addition of new barriers to medical innovation.

The **Nanotechnology Industries Association (NIA)** is a committed partner of industry that seeks to achieve these solutions. NIA also supports market intelligence in nanomedical applications and products through a nanodata service (a tender for data-providing services in support of research and policy in the field of nanosciences and nanotechnologies), commissioned by DG Research & Innovation from 2013 to 2017. The aim is to provide “systematic insights into the whole nano-value chain, from scientific research to market” and medical devices will be the first sector analyzed. Further information on NIA's support for nanomedicine commercialization can be found in the presentation of Dr. Frederick Ntow (NIA) on the ENF website at this link:

<http://www.euronanoforum2013.eu/wp-content/uploads/2013/07/F-Ntow-Market-Strategies-in-the-Medical-Device-Industry.pdf>

**DISC REGENERATION** is a project, which aims to treat intervertebral disc (IVD) degeneration via a tissue engineering (TE) approach leading to the regeneration of

the different histological compartments of the disc. The project objectives are as follows: (1) Regeneration of a healthy IVD and restoration of a physiological disc-vertebral system through appropriate bio-mimicking of the anatomy, physiology, cell biology and metabolism of the relevant natural structures; (2) Development of novel biomaterials capable of controlling angiogenesis such that it can proceed to the different extents required by different regions of the disc structure; and (3) Enhanced integration of the IVD with the adjacent vertebral body upon implantation. The presentation by Dr. Luigi Ambrosio and Dr. Luisa Tondelli can be found at the link below:

<http://www.euronanoforum2013.eu/wp-content/uploads/2013/07/L-Tondelli-Market-Strategies-in-the-Medical-Device-Industry.pdf>

**The exploitation of nanotechnology for point-of-care diagnostics** at the Biomedical Diagnostics Institute was presented by Dr. Conor Burke (Dublin City University). The Institute was established in 2005 to work on point-of-care diagnostics as one of the nine SFI CSETs. It consists of a team numbering about 150 people and is based on a broad partnership between academia, business and clinical organizations. The institute includes embedded industry researchers and has a strong focus on innovative platforms and translational research activities.

AmBeR is a point-of-care prototype device developed at the Institute; it allows for monitoring breath ammonia via printed sensor technology that uses nanoparticulate polyaniline (NanoPANI). It is a low-cost, disposable and mass-manufacturable sampler/sensor component, with a custom-designed breath sampling system. Clinical applications are Kidney/liver dysfunction and H.pylori detection. Other examples of activities are antibody optimization for biochip applications (C-reactive protein, CRP), glassy surface deposition by PECVD for polymer biochip functionalization and DiCAST (direct clone analysis and selection technologies). Further details can be found in Dr. Burke's presentation on

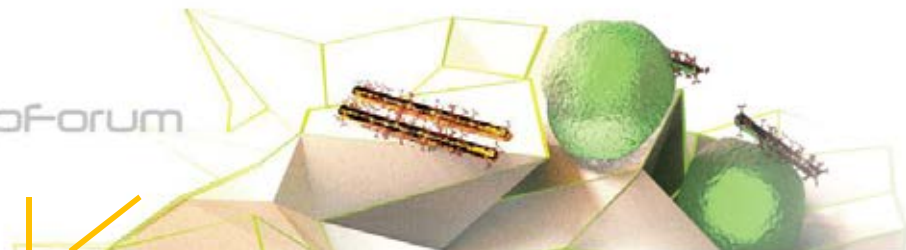

the ENF website:

<http://www.euronanoforum2013.eu/wp-content/uploads/2013/07/C-Burke-Market-Strategies-in-the-Medical-Device-Industry.pdf>

**iONE**, Implantable Organic Nano-Electronics, is an FP7 project that aims to build the knowledge and technology required to regenerate nerves at the site of injury. The use of flexible, organic, electronic devices (using ultra-thin film organic field effect transistors [FETs], organic electrochemical transistors or nanoparticle, organic memory FETs) will advance the state-of-the-art for implantable devices from passive to active layouts that will promote nerve regeneration by a combination of local stimuli delivered on demand. In addition, they will sense inflammation and control the immune-/inflammatory response. Prof. Fabio Biscarini (Università di Modena e Reggio Emilia & CNR-ISMN) presented the project, and further details are available at the following link:

<http://www.euronanoforum2013.eu/wp-content/uploads/2013/07/F-Biscarini-Market-Strategies-in-the-Medical-Device-Industry.pdf>

**Translating research to industrial innovation: Veneto Nanotech involvement in the medical sector** was the title of Dr. Pozzi Mucelli's presentation (from Veneto Nanotech). Veneto Nanotech is a cluster for nanotechnology based in the Veneto Region. Nanomedical research carried out within Veneto Nanotech includes development of innovative bio-sensing techniques, plasmonics, enhanced gene- and protein-array platforms, and antimicrobial treatments for wound dressings. It also offers support with regulatory compliance and acts as secretariat for ENM II. The presentation can be downloaded from the ENF website :

<http://www.euronanoforum2013.eu/wp-content/uploads/2013/07/S-P-Mucelli-Market-Strategies-in-the-Medical-Device-Industry.pdf>



## Dissemination Highlights

### Published journal articles, conference proceedings and book sections

#### First year (July 2010–June 2011)

1. Abbasi AZ, Gutiérrez L, del Mercato LL, Herranz F, Chubykalo-Fesenko O, Veintemillas-Verdaguer S, et al. Magnetic capsules for NMR imaging: effect of magnetic nanoparticles spatial distribution and aggregation. *The Journal of Physical Chemistry C*. 2011;115(14):6257-64.
2. Brümner R, Bonacina L, Enderlein J, Extermann J, Fricke-Begemann T, Marowsky G, et al. Evanescent-field-induced second harmonic generation by noncentrosymmetric nanoparticles. *Optics express*. 2010;18(22):23218-25.
3. Mugnier Y, Houf L, El-Kass M, Dantec RL, Hadji R, Vincent B, et al. In situ crystallization and growth dynamics of acentric iron iodate nanocrystals in w/o microemulsions probed by Hyper-Rayleigh scattering measurements. *The Journal of Physical Chemistry C*. 2010;115(1):23-30.
4. Nabiev I, Rakovich A, Sukhanova A, Lukashev E, Zagidullin V, Pachenko V, et al. Fluorescent quantum dots as artificial antennas for enhanced light harvesting and energy transfer to photosynthetic reaction centers. *Angewandte Chemie International Edition*. 2010;49(40):7217-21.
5. Rousserie G, Sukhanova A, Even-Desrumeaux K, Fleury F, Chames P, Baty D, et al. Semiconductor quantum dots for multiplexed bio-detection on solid-state microarrays. *Critical reviews in oncology/hematology*. 2010;74(1):1-15.
6. Balasubramaniam S, Boyle NT, Della-Chiesa A, Walsh F, Mardinoglu A, Botvich D, et al. Development of artificial neuronal networks for molecular communication. *Nano Communication Networks*. 2011;2(2):150-60.
7. Bouchonville N, Molinari M, Sukhanova A, Artemyev M, Oleinikov VA, Troyon M, et al. Charge-controlled assembling of bacteriorhodopsin and semiconductor quantum dots for fluorescence resonance energy transfer-based nanophotonic applications. *Applied Physics Letters*. 2011;98(1):013703.
8. Mahmoud W, Rousserie G, Reveil B, Tabary T, Millot J-M, Artemyev M, et al. Advanced procedures for labeling of antibodies with quantum dots. *Analytical biochemistry*. 2011;416(2):180-5.
9. Monzon L, Byrne F, Coey J. Gold electrodeposition in organic media. *Journal of Electroanalytical Chemistry*. 2011;657(1):54-60.
10. Murphy FA, Poland CA, Duffin R, Al-Jamal KT, Ali-Boucetta H, Nunes A, et al. Length-dependent retention of carbon nanotubes in the pleural space of mice initiates sustained inflammation and progressive fibrosis on the parietal pleura. *The American journal of pathology*. 2011;178(6):2587-600.
11. Rakovich T, Prina-Mello a, Rakovich A, Byrne S, Atzberger A, McCarthy J, et al., editors. Application of nanomaterials in nanomedicine research. *Physics, Chemistry and Applications of Nanostructures: Proceedings of the International Conference Nanomeeting--2011: Reviews and Short Notes: Minsk, Belarus, 24-27 May 2011*; 2011: World Scientific.
12. Strobel S, Sperling RA, Fenk B, Parak WJ, Tornow M. Dielectrophoretic trapping of DNA-coated gold nanoparticles on silicon based vertical nanogap devices. *Physical Chemistry Chemical Physics*. 2011;13(21):9973-7.
13. Movia D, Prina-Mello A, Volkov Y, Giordani S. Determination of spiropyran cytotoxicity by high content screening and analysis for safe application in bionanosensing. *Chemical research in toxicology*. 2010;23(9):1459-66.
14. Rousserie, G., Mahmoud, W., Even-Desrumeaux, K., Kisserli, A., Poly, S., Reveil, B., Tabary, T., Chames, P., Baty, D., Millot, J.-M., Pluot, M., Cohen, J.H.M., Nabiev, I., and Sukhanova, A. Advanced labeling of monoclonal and single-domain antibodies with quantum dots: toward new generation of ultra-small specific nanoprobe. *Proceedings of the 7th International Conference on Biomedical Applications of Nanotechnology 2010* p.34-35 (NanoMed2010, Berlin, 2-3 Dec 2010).



## Second year (July 2011–June 2012)

15. Amin F, Yushchenko DA, Montenegro JM, Parak WJ. Integration of Organic Fluorophores in the Surface of Polymer-Coated Colloidal Nanoparticles for Sensing the Local Polarity of the Environment. *ChemPhysChem*. 2012;13(4):1030-5.
16. Byrne FN, Monzon L, Stamenov P, Venkatesan M, Coey J. Influence of an Au capping layer on the magnetic properties of CoPt nanowires. *Applied Physics Letters*. 2011;98(25):252507--3.
17. Carregal-Romero S, Montenegro J-M, Parak WJ, Rivera\_Gil P. Subcellular carrier-based optical ion-selective nanosensors. *Frontiers in pharmacology*. 2012;3.
18. Colombo M, Carregal-Romero S, Casula MF, Gutiérrez L, Morales MP, Böhm IB, et al. Biological applications of magnetic nanoparticles. *Chemical Society Reviews*. 2012;41(11):4306-34.
19. del Mercato LL, Abbasi AZ, Ochs M, Parak WJ. Multiplexed sensing of ions with barcoded polyelectrolyte capsules. *ACS nano*. 2011;5(12):9668-74.
20. Dieckhoff J, Schilling M, Ludwig F. Fluxgate based detection of magnetic nanoparticle dynamics in a rotating magnetic field. *Applied Physics Letters*. 2011;99(11):112501.
21. Geissbuehler M, Bonacina L, Shcheslavskiy V, Bocchio NL, Geissbuehler S, Leutenegger M, et al. Nonlinear correlation spectroscopy (NLCS). *Nano letters*. 2012;12(3):1668-72.
22. Hardzei M, Artemyev M, Molinari M, Troyon M, Sukhanova A, Nabiev I. Comparative efficiency of energy transfer from CdSe–ZnS quantum dots or nanorods to organic dye molecules. *ChemPhysChem*. 2012;13(1):330-5.
23. Jimenez de Aberasturi D, Montenegro J-M, Ruiz de Larramendi I, Rojo Tf, Klar TA, Alvarez-Puebla R, et al. Optical sensing of small ions with colloidal nanoparticles. *Chemistry of Materials*. 2012;24(5):738-45.
24. Kiselev D, Bonacina L, Wolf J-P. Individual bioaerosol particle discrimination by multi-photon excited fluorescence. *Optics express*. 2011;19(24):24516-21.
25. Khalid W, El Helou M, Murböck T, Yue Z, Montenegro J-M, Schubert K, et al. Immobilization of quantum dots via conjugated self-assembled monolayers and their application as a light-controlled sensor for the detection of hydrogen peroxide. *ACS nano*. 2011;5(12):9870-6.
26. Knyazev A, Louise L, Veber M, Langevin D, Filoramo A, Prina-Mello A, et al. Selective Adsorption of Proteins on Single-Wall Carbon Nanotubes by Using a Protective Surfactant. *Chemistry-A European Journal*. 2011;17(51):14663-71.
27. Le Dantec R, Mugnier Y, Djanta G, Bonacina L, Extermann J, Badie L, et al. Ensemble and individual characterization of the nonlinear optical properties of ZnO and BaTiO<sub>3</sub> nanocrystals. *The Journal of Physical Chemistry C*. 2011;115(31):15140-6.
28. Mahmoud W, Rousserie G, Reveil B, Tabary T, Millot J-M, Artemyev M, et al. Advanced procedures for labeling of antibodies with quantum dots. *Analytical biochemistry*. 2011;416(2):180-5.
29. McCarthy JE, Prina-Mello A, Rakovich T, Volkov Y, Gun'ko YK. Fabrication and characterization of multimodal magnetic-fluorescent polystyrene nanowires as selective cell imaging probes. *Journal of Materials Chemistry*. 2011;21(37):14219-25.
30. Mohamed BM, Verma NK, Davies AM, McGowan A, Crosbie-Staunton K, Prina-Mello A, et al. Citrullination of proteins: a common post-translational modification pathway induced by different nanoparticles in vitro and in vivo. *Nanomedicine*. 2012;7(8):1181-95.
31. Mohamed BM, Verma NK, Prina-Mello A, Williams Y, Davies AM, Bakos G, et al. Activation of stress-related signalling pathway in human cells upon SiO<sub>2</sub> nanoparticles exposure as an early indicator of cytotoxicity. *J Nanobiotechnology*. 2011;9:29.
32. Movia D, Prina-Mello A, Bazou D, Volkov Y, Giordani S. Screening the cytotoxicity of single-walled carbon nanotubes using novel 3D tissue-mimetic models. *ACS nano*. 2011;5(11):9278-90.
33. Parak WJ. Materials science. Complex colloidal assembly. *Science*. 2011;334(6061):1359-60.
34. Santos-Martínez MJ, Prina-Mello A, Medina C, Radomski MW. Analysis of platelet function: role of microfluidics and nanodevices. *Analyst*. 2011;136(24):5120-6.
35. Prudnikau A, Artemyev M, Molinari M, Troyon M, Sukhanova A, Nabiev I, et al. Chemical substitution of Cd ions by Hg in CdSe nanorods and nanodots: Spectroscopic and structural examination. *Materials Science and Engineering: B*. 2012;177(10):744-9.
36. Samuel SP, Jain N, O'Dowd F, Paul T, Kashanin D, Gerard VA, et al. Multifactorial determinants that govern nanoparticle uptake by human endothelial cells under flow. *International journal of nanomedicine*. 2012;7:2943-56.



37. Shemetov AA, Nabiev I, Sukhanova A. Molecular interaction of proteins and peptides with nanoparticles. *ACS nano*. 2012;6(6):4585-602.
38. Schrittwieser S, Ludwig F, Dieckhoff J, Soulantica K, Viau G, Lacroix L-M, et al. Modeling and Development of a Biosensor Based on Optical Relaxation Measurements of Hybrid Nanoparticles. *ACS nano*. 2011;6(1):791-801.
39. Schinwald A, Murphy F, Prina-Mello A, Poland C, Byrne F, Glass J, et al. The threshold length for fibre-induced acute pleural inflammation: shedding light on the early events in asbestos-induced mesothelioma. *Toxicological Sciences*. 2012:kfs171.
40. Staedler D, Magouroux T, Hadji R, Joulaud C, Extermann J, Schwung S, et al. Harmonic nanocrystals for biolabeling: a survey of optical properties and biocompatibility. *ACS Nano*. 2012;6(3):2542-9.
41. Sukhanova A, Even-Desrumeaux K, Chames P, Baty D, Artemyev M, Oleinikov V, et al. Engineering of ultra-small diagnostic nanoprobe through oriented conjugation of single-domain antibodies and quantum dots. *Protocol Exchange* 2012.
42. Sukhanova A, Even-Desrumeaux K, Kisserli A, Tabary T, Reveil B, Millot J-M, et al. Oriented conjugates of single-domain antibodies and quantum dots: toward a new generation of ultrasmall diagnostic nanoprobe. *Nanomedicine: nanotechnology, biology and medicine*. 2012;8(4):516-25.
43. Sukhanova A, Even-Desrumeaux K, Millot J-M, Chames P, Baty D, Artemyev M, et al., editors. Oriented conjugates of monoclonal and single-domain antibodies with quantum dots for flow cytometry and immunohistochemistry diagnostic applications. *SPIE BiOS; 2012: International Society for Optics and Photonics*.
44. Sukhanova A, Poly S, Shemetov A, Bronstein I, Nabiev I. Implications of protein structure instability: From physiological to pathological secondary structure. *Biopolymers*. 2012;97(8):577-88.
45. Yoshida T, Enpuku K, Dieckhoff J, Schilling M, Ludwig F. Magnetic fluid dynamics in a rotating magnetic field. *Journal of Applied Physics*. 2012;111(5):053901.

### Third year (July 2012–June 2013)

46. Åkesson A, Cárdenas M, Elia G, Monopoli MP, Dawson KA. The protein corona of dendrimers: PAMAM binds and activates complement proteins in human plasma in a generation dependent manner. *RSC Advances*. 2012;2(30):11245-8.
47. Akinfiyeva O, Nabiev I, Sukhanova A. New directions in quantum dot-based cytometry detection of cancer serum markers and tumour cells. *Critical reviews in oncology/hematology*. 2013;86(1):1-14.
48. Artemyev M, Nabiev I. Molecular beacons involving highly luminescent colloidal quantum dots. *Journal of Nanophotonics*. 2012;6(1):060304-.
49. Bobrovsky A, Mochalov K, Oleinikov V, Sukhanova A, Prudnikau A, Artemyev M, et al. Optically and electrically controlled circularly polarized emission from cholesteric liquid crystal materials doped with semiconductor quantum dots. *Advanced Materials*. 2012;24(46):6216-22.
50. Bonacina L. Nonlinear Nanomedicine: Harmonic Nanoparticles toward Targeted Diagnosis and Therapy. *Molecular pharmaceuticals*. 2012;10(3):783-92.
51. Bonacina L, Magouroux T, Rogov A, Staedler D, Joulaud C, Schwung S, et al., editors. Harmonic nanoparticles for nonlinear bio-imaging and detection. *SPIE LASE; 2013: International Society for Optics and Photonics*.
52. Bonacina L, Wolf J-P. Coherent Control of Biomolecules and Imaging Using Nanodoublers. *Nano-Optics for Enhancing Light-Matter Interactions on a Molecular Scale: Springer Netherlands; 2013*. p. 251-69. Book chapter
53. Bouchonville N, Le Cigne A, Sukhanova A, Saab M-b, Troyon M, Molinari M, et al., editors. Controlled FRET efficiency in nano-bio hybrid materials made from semiconductor quantum dots and bacteriorhodopsin. *SPIE NanoScience+ Engineering; 2012: International Society for Optics and Photonics*.
54. Bouchonville N, Le Cigne A, Sukhanova A, Molinari M, Nabiev I. Nano-biophotonic hybrid materials with controlled FRET efficiency engineered from quantum dots and bacteriorhodopsin. *Laser Physics Letters*. 2013;10(8):085901.
55. Bouchonville N, Molinari M, Le Cigne A, Troyon M, Sukhanova A, Nabiev IR, editors. Semiconductor quantum dots affect fluidity of purple membrane from *Halobacterium salinarum* through disruption of bacteriorhodopsin trimer organization. *SPIE Nanosystems in Engineering+ Medicine; 2012: International Society for Optics and Photonics*.
56. Chen J, Carroll N, Feng J, Coey J. Yoke-shaped MgO-barrier magnetic tunnel junction sensors. *Applied Physics Letters*. 2012;101(26):262402.
57. Cormary B, Dumestre F, Liakakos N, Soulantica K, Chaudret B. Organometallic precursors of nano-objects, a critical view. *Dalton Transactions*. 2013;42(35):12546-53.



58. Dieckhoff JH, Yoshida T, Enpuku K, Schilling M, Ludwig F. Homogeneous Bioassays Based on the Manipulation of Magnetic Nanoparticles by Rotating and Alternating Magnetic Fields—A Comparison. *Magnetics, IEEE Transactions on*. 2012;48(11):3792-5.
59. Esmaeily A, Venkatesan M, Razavian AS, Coey J. Diameter-modulated ferromagnetic CoFe nanowires. *Journal of Applied Physics*. 2013;113(17):17A327.
60. Gao Y, Mohamed B, Prina-Mello A, O'Byrne K, Gray S. 85 KAT5 and KDM6B may be candidate therapeutic targets in malignant pleural mesothelioma. *Lung Cancer*. 2013;79(Supplement 1).
61. Generalova AN, Oleinikov VA, Sukhanova A, Artemyev MV, Zubov VP, Nabiev I, editors. Biosensing with thermosensitive fluorescent quantum dot-containing polymer particles. *SPIE NanoScience+ Engineering*; 2012: International Society for Optics and Photonics.
62. Generalova AN, Oleinikov VA, Sukhanova A, Artemyev MV, Zubov VP, Nabiev I. Quantum dot-containing polymer particles with thermosensitive fluorescence. *Biosensors and Bioelectronics*. 2013;39(1):187-93.
63. Gérard VA, Freeley M, Defrancq E, Fedorov AV, Gun'ko YK. Optical properties and in vitro biological studies of oligonucleotide-modified quantum dots. *Journal of Nanomaterials*. 2013;2013:3.
64. Gun'ko YK and Byrne S, Chapter : Quantum Dot Synthesis Methods in the book "Quantum Dot Sensors: Technology and Commercial Applications", - 230 Pages Editor(s): John Callan; Francisco , M. Raymo , ISBN-10: 9814316008, Pan Stanford Publishing. January, 2013. (INVITED BOOK CHAPTER)
65. Hafian H, Sukhanova A, Chames P, Baty D, Pluot M, Cohen JH, et al., editors. Bi-photon imaging and diagnostics using ultra-small diagnostic probes engineered from semiconductor nanocrystals and single-domain antibodies. *SPIE Nanosystems in Engineering+ Medicine*; 2012: International Society for Optics and Photonics.
66. Kotkovskiy GE, Kuzishchin YA, Martynov IL, Chistyakov AA, Nabiev I. The photophysics of porous silicon: technological and biomedical implications. *Physical Chemistry Chemical Physics*. 2012;14(40):13890-902.
67. Ladj R, Bitar A, Eissa M, Mugnier Y, Le Dantec R, Fessi H, et al. Individual inorganic nanoparticles: preparation, functionalization and in vitro biomedical diagnostic applications. *Journal of Materials Chemistry B*. 2013;1(10):1381-96.
68. Ladj R, El Kass M, Mugnier Y, Le Dantec R, Fessi H, Galez C, et al. SHG Active Fe (IO<sub>3</sub>)<sub>3</sub> Particles: From Spherical Nanocrystals to Urchin-Like Microstructures through the Additive-Mediated Microemulsion Route. *Crystal Growth & Design*. 2012;12(11):5387-95.
69. Mahmoudi M, Monopoli MP, Rezaei M, Lynch I, Bertoli F, McManus JJ, et al. The Protein Corona Mediates the Impact of Nanomaterials and Slows Amyloid Beta Fibrillation. *ChemBioChem*. 2013;14(5):568-72.
70. Magouroux T, Extermann J, Hoffmann P, Mugnier Y, Le Dantec R, Jaconi ME, et al. High-Speed Tracking of Murine Cardiac Stem Cells by Harmonic Nanodoublers. *small*. 2012;8(17):2752-6.
71. Mochalov KE, Bobrovsky AY, Oleinikov VA, Sukhanova AV, Efimov AE, Shibaev V, et al., editors. Novel cholesteric materials doped with CdSe/ZnS quantum dots with photo-and electro-tunable circularly polarized emission. *SPIE Organic Photonics+ Electronics*; 2012: International Society for Optics and Photonics.
72. Mochalov KE, Efimov AE, Bobrovsky AY, Agapov II, Chistyakov AA, Oleinikov VA, et al., editors. High-resolution 3D structural and optical analyses of hybrid or composite materials by means of scanning probe microscopy combined with the ultramicrotome technique: an example of application to engineering of liquid crystals doped with fluorescent quantum dots. *SPIE Microtechnologies*; 2013: International Society for Optics and Photonics.
73. Mohamed BM, Movia D, Knyazev A, Langevin D, Davies AM, Prina-Mello A, et al. Citrullination as early-stage indicator of cell response to Single-Walled Carbon Nanotubes. *Scientific reports*. 2013;3.
74. Monopoli MP, Pitek AS, Lynch I, Dawson KA. Formation and Characterization of the Nanoparticle-Protein Corona. *Nanomaterial Interfaces in Biology*: Springer; 2013. p. 137-55. (Bergese & Hamad-Schifferli Eds., Book chapter: ISBN 978-1-62703-461-6).
75. Montenegro J-M, Grazu V, Sukhanova A, Agarwal S, de la Fuente JM, Nabiev I, et al. Controlled antibody/(bio-) conjugation of inorganic nanoparticles for targeted delivery. *Advanced drug delivery reviews*. 2013;65(5):677-88.
76. Monzon L, O'Neill K, Sheth Y, Venkatesan M, Coey J. Fabrication of multisegmented magnetic wires with micron-length copper spacers. *Electrochemistry Communications*. 2013;36:96-8.
77. Passemard S, Staedler D, Učňová L, Schneiter GS, Kong P, Bonacina L, et al. Convenient synthesis of heterobifunctional poly (ethylene glycol) suitable for the functionalization of iron oxide nanoparticles for biomedical applications. *Bioorganic & medicinal chemistry letters*. 2013;23(17):5006-10.
78. Oleinikov V, Bouchonville N, Sukhanova A, Molinari M, Sizova S, Mochalov K, et al., editors. Extension of the spectral range of bacteriorhodopsin functional activity by energy transfer from quantum dots. *SPIE NanoScience+ Engineering*; 2012: International Society for Optics and Photonics.

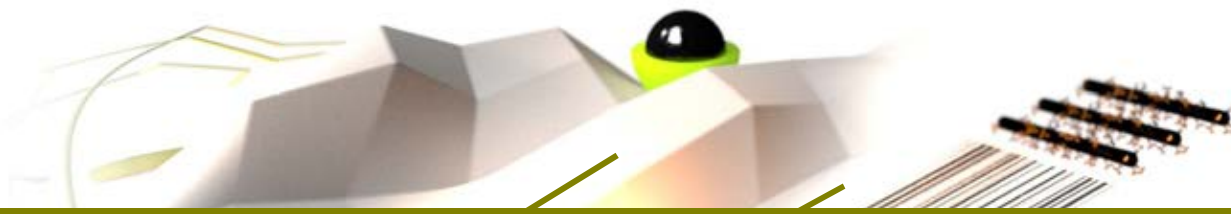

79. Poland CA, Byrne F, Cho W-S, Prina-Mello A, Murphy FA, Davies GL, et al. Length-dependent pathogenic effects of nickel nanowires in the lungs and the peritoneal cavity. *Nanotoxicology*. 2012;6(8):899-911.
80. Prina-Mello A, Crosbie-Staunton K, Salas G, del Puerto Morales M, Volkov Y. Multiparametric Toxicity Evaluation of SPIONs by High Content Screening Technique: Identification of Biocompatible Multifunctional Nanoparticles for Nanomedicine. *Magnetics, IEEE Transactions on*. 2013;49(1):377-82.
81. Rakovich A, Nabiev I, Sukhanova A, Lesnyak V, Gaponik N, Rakovich YP, et al. Large Enhancement of Nonlinear Optical Response in a Hybrid Nanobiomaterial Consisting of Bacteriorhodopsin and Cadmium Telluride Quantum Dots. *ACS nano*. 2013;7(3):2154-60.
82. Rivera-Gil P, Jimenez De Aberasturi D, Wulf V, Pelaz B, Del Pino P, Zhao Y, et al. The challenge to relate the physico-chemical properties of colloidal nanoparticles to their cytotoxicity. *Accounts of chemical research*. 2012;46(3):743-9.
83. Salvati A, Pitek AS, Monopoli MP, Prapainop K, Bombelli FB, Hristov DR, et al. Transferrin-functionalized nanoparticles lose their targeting capabilities when a biomolecule corona adsorbs on the surface. *Nature nanotechnology*. 2013;8(2):137-43.
84. Samokhvalov P, Artemyev M, Nabiev I. Basic Principles and Current Trends in Colloidal Synthesis of Highly Luminescent Semiconductor Nanocrystals. *Chemistry-A European Journal*. 2013;19(5):1534-46.
85. Samokhvalov P, Artemyev M, Nabiev I. Current methods of the synthesis of luminescent semiconductor nanocrystals for biomedical applications. *Nanotechnologies in Russia*. 2013;8(5-6):409-22.
86. Samuel SP, Jain N, O'Dowd F, Paul T, Kashanin D, Gerard VA, et al. Multifactorial determinants that govern nanoparticle uptake by human endothelial cells under flow. *International journal of nanomedicine*. 2012;7:2943-56.
87. Schweiger C, Hartmann R, Zhang F, Parak WJ, Kissel TH, Rivera\_Gil P. Quantification of the internalization patterns of superparamagnetic iron oxide nanoparticles with opposite charge. *Journal of nanobiotechnology*. 2012;10(1):28.
88. Shvedova AA, Kapralov AA, Feng WH, Kisin ER, Murray AR, Mercer RR, et al. Impaired clearance and enhanced pulmonary inflammatory/fibrotic response to carbon nanotubes in myeloperoxidase-deficient mice. *PLoS One*. 2012;7(3):e30923.
89. Soenen SJ, Manshian B, Montenegro JM, Amin F, Meermann Br, Thiron T, et al. Cytotoxic effects of gold nanoparticles: a multiparametric study. *ACS nano*. 2012;6(7):5767-83.
90. Sukhanova A, Poly S, Shemetov A, Nabiev IR, editors. Quantum dots induce charge-specific amyloid-like fibrillation of insulin at physiological conditions. *SPIE Nanosystems in Engineering+ Medicine; 2012: International Society for Optics and Photonics*.
91. Verma NK, Conroy J, Lyons PE, Coleman J, O'Sullivan MP, Kornfeld H, et al. Autophagy induction by silver nanowires: A new aspect in the biocompatibility assessment of nanocomposite thin films. *Toxicology and applied pharmacology*. 2012;264(3):451-61.
92. Zaitsev SY, Solovyeva DO, Nabiev I. Thin films and assemblies of photosensitive membrane proteins and colloidal nanocrystals for engineering of hybrid materials with advanced properties. *Advances in colloid and interface science*. 2012;183:14-29.
93. Zakharko Y, Nychporuk T, Bonacina L, Lemiti M, Lysenko V. Plasmon-enhanced nonlinear optical properties of SiC nanoparticles. *Nanotechnology*. 2013;24(5):055703.

#### **Fourth year (from July 2013)**

94. Brazhnik K, Grinevich R, Efimov AE, Nabiev I, Sukhanova A, editors. Development and potential applications of microarrays based on fluorescent nanocrystal-encoded beads for multiplexed cancer diagnostics. *SPIE Photonics Europe; 2014: International Society for Optics and Photonics*.
95. Dayneko S, Tameev A, Tedoradze M, Martynov I, Linkov P, Samokhvalov P, et al., editors. Hybrid bulk heterojunction solar cells based on low band gap polymers and CdSe nanocrystals. *SPIE OPTO; 2014: International Society for Optics and Photonics*.
96. Dieckhoff J, Lak A, Schilling M, Ludwig F. Protein detection with magnetic nanoparticles in a rotating magnetic field. *Journal of Applied Physics*. 2014;115(2):024701.
97. Dieckhoff J, Schilling M, Ludwig F. Magnetic marker based homogeneous bioassays utilizing rotating magnetic fields. *Journal of Applied Physics*. 2014;115(17):17B304.
98. El-Kass M, Ladj R, Mugnier Y, Le Dantec R, Hadji R, Marty J-C, et al. Temperature-dependent adsorption of surfactant molecules and associated crystallization kinetics of noncentrosymmetric Fe (IO<sub>3</sub>)<sub>3</sub> nanorods in microemulsions. *Materials Research Bulletin*. 2013;48(11):4431-7.



99. Even-Desrumeaux K, Nevoltris D, Lavaut MN, Alim K, Borg J-P, Audebert S, et al. Masked selection: a straightforward and flexible approach for the selection of binders against specific epitopes and differentially expressed proteins by phage display. *Molecular & Cellular Proteomics*. 2014;13(2):653-65.
100. Gerard VA, K. Gun'ko Y, *Nanoscience: Volume 2, 2014, 2, 1-22; Chapter 1:Gold and silver nanostructures of controlled shape, RSC Nanoscience & Nanotechnology series. (INVITED BOOK CHAPTER)*
101. Hole P, Sillence K, Hannell C, Maguire CM, Roesslein M, Suarez G, et al. Interlaboratory comparison of size measurements on nanoparticles using nanoparticle tracking analysis (NTA). *Journal of Nanoparticle Research*. 2013;15(12):1-12. DICEMBRE 2013
102. Houf L, Mugnier Y, Rouxel D, Dantec R, Badie L, Vincent B, et al. Preparation of transparent PMMA/Fe (IO<sub>3</sub>)<sub>3</sub> nanocomposite films from microemulsion polymerization. *Journal of Applied Polymer Science*. 2013;130(2):1203-11.
103. Ibrahim M, Marcelot-Garcia Cc, Ait Atmane K, Berrichi E, Lacroix L-M, Zwick A, et al. Carbon Coating, Carburization, and High-Temperature Stability Improvement of Cobalt Nanorods. *The Journal of Physical Chemistry C*. 2013;117(30):15808-16.
104. Joulaud C, Mugnier Y, Djanta G, Dubled M, Marty J-C, Galez C, et al. Characterization of the nonlinear optical properties of nanocrystals by Hyper Rayleigh Scattering. *Journal of Nanobiotechnology*. 2013;11(Suppl 1):S8.
105. Krivenkov VA, Samokhvalov PS, Linkov PA, Solovyeva DO, Kotkovskiy GE, Chistyakov AA, et al., editors. Surface ligands affect photoinduced modulation of the quantum dots optical performance. *SPIE Photonics Europe; 2014: International Society for Optics and Photonics*.
106. Ladj R, Bitar A, Eissa MM, Fessi H, Mugnier Y, Le Dantec R, et al. Polymer encapsulation of inorganic nanoparticles for biomedical applications. *International journal of pharmaceutics*. 2013;458(1):230-41.
107. Ladj R, Eissa MM, Valour J-P, Mugnier Y, Le Dantec R, Fessi H, et al. Towards a One-Step Synthesis and Encapsulation of Acentric Iron Iodate (Fe (IO<sub>3</sub>)<sub>3</sub>) Nanocrystals via Inverse Miniemulsion. *Science of Advanced Materials*. 2014;6(1):102-10.
108. Ladj R, Magouroux T, Eissa M, Dubled M, Mugnier Y, Dantec RL, et al. Aminodextran-coated potassium niobate (KNbO<sub>3</sub>) nanocrystals for second harmonic bio-imaging. *Colloids and Surfaces A: Physicochemical and Engineering Aspects*. 2013;439:131-7.
109. Liakakos N, Gatel C, Blon T, Altantzis T, Lentijo-Mozo S, Garcia-Marcelot C, et al. Co-Fe Nano-dumbbells: Synthesis, Structure and Magnetic Properties. *Nano letters*. 2014.
110. Liakakos N, Blon T, Achkar C, Vilar V, Cormary B, Tan RP, et al. Solution Epitaxial Growth of Cobalt Nanowires on Crystalline Substrates for Data Storage Densities Beyond 1Tbit/in<sup>2</sup>. *Nano letters*. 2014.
111. Linkov P, Artemyev M, Efimov AE, Nabiev I. Comparative advantages and limitations of the basic metrology methods applied to the characterization of nanomaterials. *Nanoscale*. 2013;5(19):8781-98.
112. Maguire CM, Mahfoud OK, Rakovich T, Gerard VA, Prina-Mello A, Gun'ko Y, et al. Heparin conjugated quantum dots for *in vitro* imaging applications. *Nanomedicine: Nanotechnology, Biology and Medicine*. 2014.
113. Mahfoud OK, Rakovich TY, Prina-Mello A, Movia D, Alves F, Volkov Y. Detection of ErbB2: nanotechnological solutions for clinical diagnostics. *RSC Advances*. 2014;4(7):3422-42.
114. Mochalov KE, Efimov AE, Bobrovsky A, Agapov II, Chistyakov AA, Oleinikov V, et al. Combined Scanning Probe Nanotomography and Optical Microspectroscopy: A Correlative Technique for 3D Characterization of Nanomaterials. *ACS nano*. 2013;7(10):8953-62.
115. Movia D, Gerard V, Maguire CM, Jain N, Bell AP, Nicolosi V, et al. A safe-by-design approach to the development of gold nanoboxes as carriers for internalization into cancer cells. *Biomaterials*. 2014.
116. Prina-Mello A, Mohamed BM, Verma NK, Jain N, Volkov Y, Book Chapter 9 titled: "Advanced Methodologies and Techniques for Assessing Nanomaterial Toxicity", Book: *Nanotoxicology: Progress toward Nanomedicine 2014*, CRC Press, Editor Lang and Monteiro-Riviera, Available since 2014/2/28. (INVITED BOOK CHAPTER)
117. Rakovich A, Donegan JF, Oleinikov V, Molinari M, Sukhanova A, Nabiev I, et al. Linear and nonlinear optical effects induced by energy transfer from semiconductor nanoparticles to photosynthetic biological systems. *Journal of Photochemistry and Photobiology C: Photochemistry Reviews*. 2014;20:17-32.
118. Rakovich TY, Mahfoud OK, Mohamed BM, Prina-Mello A, Crosbie-Staunton K, Van den Broeck T, et al. Highly Sensitive Single Domain Antibody-Quantum Dot Conjugates for Detection of HER2 Biomarker in Lung and Breast Cancer Cells. *ACS nano*. 2014.
119. Renugopalakrishnan V, Barbiellini B, King C, Molinari M, Mochalov K, Sukhanova A, et al. Engineering a Robust Photovoltaic Device with Quantum Dots and Bacteriorhodopsin. *The Journal of Physical Chemistry C*. 2014.





120. Riou O, Lonetti B, Davidson P, Tan RP, Cormary B, Mingotaud A-F, et al. Liquid Crystalline Polymer–Co Nanorod Hybrids: Structural Analysis and Response to a Magnetic Field. *The Journal of Physical Chemistry B*. 2014;118(11):3218-25.
121. Rotoli BM, Gatti R, Movia D, Bianchi MG, Di Cristo L, Fenoglio I, et al. Identifying contact-mediated, localized toxic effects of MWCNT aggregates on epithelial monolayers: a single-cell monitoring toxicity assay. *Nanotoxicology*. 2014(0):1-12.
122. Ronzoni F, Magouroux T, Vernet R, Extermann J, Crotty D, Prina-Mello A, et al. Harmonic Nanoparticles for Regenerative Research. *JoVE (Journal of Visualized Experiments)*. 2014(87):e51333-e.
123. Rumyantsev K, Shemetov A, Nabiev I, Sukhanova A. Structural and functional aspects of the interaction of proteins and peptides with nanoparticles. *Nanotechnologies in Russia*. 2013;8(11-12):700-20.
124. Samokhvalov P, Linkov P, Michel J, Molinari M, Nabiev I, editors. Photoluminescence quantum yield of CdSe-ZnS/CdS/ZnS core-multishell quantum dots approaches 100% due to enhancement of charge carrier confinement. *SPIE BiOS*; 2014: International Society for Optics and Photonics.
125. Schrittwieser S, Ludwig F, Dieckhoff J, Tschoepe A, Guenther A, Richter M, et al. Direct protein detection in the sample solution by monitoring rotational dynamics of nickel nanorods. *Small*. 2014;10(2):407-11.
126. Soenen SJ, Montenegro J-M, Abdelmonem AM, Manshian BB, Doak SH, Parak WJ, et al. The effect of nanoparticle degradation on poly (methacrylic acid)-coated quantum dot toxicity: The importance of particle functionality assessment in toxicology. *Acta biomaterialia*. 2014;10(2):732-41.
127. Staedler D, Magouroux T, Passermard S, Schwung S, Dumbled M, Schneiter GS, et al. Deep UV generation and direct DNA photo-interaction by harmonic nanoparticles in labelled samples. *Nanoscale*. 2014;6(5):2929-36.
128. Singh M, Movia D, Mahfoud OK, Volkov Y, Prina-Mello A. Silver nanowires as prospective carriers for drug delivery in cancer treatment: an in vitro biocompatibility study on lung adenocarcinoma cells and fibroblasts. *European Journal of Nanomedicine*. 2013;5(4):195-204.
129. Zaitsev SYe, Solovyeva D, Nabiev IR. Nano-biohybrid structures based on the organized films of photosensitive membrane proteins. *Russian Chemical Reviews*. 2014;83(1):38-81.
130. Yu X, Lei DY, Amin F, Hartmann R, Acuna GP, Guerrero-Martínez A, et al. Distance control in-between plasmonic nanoparticles via biological and polymeric spacers. *Nano Today*. 2013;8(5):480-93.

### Accepted/in press

131. Brazhnik K, Nabiev I, Sukhanova A (2013) Oriented conjugation of single-domain antibodies and quantum dots. *Methods in Molecular Biology* accepted
132. Brazhnik K, Nabiev I, Sukhanova A (2013) Advanced procedure for oriented conjugation of full-size antibodies with quantum dots. *Methods in Molecular Biology*, accepted
133. Grinevich, R., Nabiev, I. Fleury, F., Sukhanova, A. (2013) Quantum dots for accurate cell targeting, imaging, and drug delivery. *Expert Opinion on Drug Delivery*, accepted.
134. Hafian, H., Sukhanova, A., Turinic, M., Chames, P., Baty, D., Pluot, M., Cohen, JHM, Nabiev, I., Millot, JM. (2013) Multiphoton imaging of tumour biomarkers with the conjugates of single-domain antibodies and quantum dots. *Nanomedicine: NBM*, submitted
135. Sizova SV, Oleinikov VA, Bouchonville N, Molinari M, Sukhanova A, Nabiev I Energy transfer mechanisms in nano-bio hybrid structures based on quantum dots and photosensitive membrane proteins. In: Haacke S., ed. *Fast Life-Time Dynamics in Proteins*, Date of publication: June 30, 2014 by Pan Stanford Publishing - 300 pp. in press.
136. Williams, Y., Sukhanova, A., Conroy, J., Mohamed, B., Davies, A., Oleinikov, V., Artemyev, M., Kelleher, D., Nabiev, I., Volkov, Y. (2013) Surface density of charged functional groups on quantum dots defines their intracellular compartmentalization and biocompatibility. *Nanomedicine: NBM*, submitted.



## Conferences and seminars: Invited talks, oral communications and posters

### First year (July2010–June2011)

1. Alves F, Optical Imaging Workshop List of Speakers: Luigi Bonacina - Second harmonic imaging nano-probes for bio-LABELING. Yuri Volkow - "Nano-Barriers" and "Nano-Carriers": Advanced imaging approaches for nanoparticle uptake and intracellular targeting. Colin Self - Directing antibodies by light - the clinical consequences. 25-26.11.2010 Max-Planck-Institute of Experimental Medicine, Göttingen - Germany
2. Bonacina L, Second harmonic imaging probes for biolabeling 19/10/2010 Seminar Coherent Raman Scattering Microscopy (microCARS2010), Physikzentrum Bad Honnef (Germany)
3. Bonacina L, Nonlinear imaging probes 26/11/2010 Optical Imaging Workshop, University Medical Center Göttingen (Germany)
4. Bonacina L, Second harmonic nano-particles for bio-imaging 14/02/2011 Workshop on bio-applications of SiC nanoparticles. INSA de Lyon, IMBL
5. Byrne F, Magnetic Barcodes in Molecular Medicine 03/11/2010 Department of Physics, Dublin, Ireland
6. Chen M, NAMDIATREAM Project - Nanotechnological toolkits for Multi-modal disease 15/06/2011 Bio Nanotech 2011, one of the conferences of the TechConnect World 2011 event (Boston, MA, USA)
7. Conroy J, Prina Mello A, An *in vitro* integrated ultrasensitive approach to biocompatibility analysis of silver 14/02/2011 Nanoimpactnet conference, Lausanne (Switzerland)
8. Conroy J, Investigation of carbon nanotube degradation in vitro and in vivo using Raman spectroscopy 14/06/2011 TechConnect 2011, Boston MA, USA
9. Crotty D, An Investigation into the Effects of Magnetic Fields on Biological Cell Processes 15/12/2010 Department of Physics and Biochemistry, Dublin, Ireland
10. El Kass M, Hyper Rayleigh Scattering : a means fo investigating the growth mechanism of nanocrystals w 27/10/2010 EOS Annual Meeting 2010, Paris (France)
11. El Kass M, Growth and formation dynamics of acentric dielectric nanoparticles in reverse microemulsions 09/05/2011 Colloids and Materials 2011, Amsterdam
12. Franceschini P. NAMDIATREAM Project - Nanotechnological toolkits for Multi-modal disease 14/06/2011 SAN-IT2011, an international forum on health, Rome, Italy
13. Geissbuehler M, Characterization of Nanoparticles Using Non-linear Correlation Spectroscopy 23/05/2011 ECBO 2011 - European Conferences on Biomedical Optics, Munich
14. Inness-Turnbull M, Duffin G, Dessi J, Thompson S, Self CH, Rapid accurate testing systems for marker 14/03/2011 Winter-Workshop Clinical, Chemical and Biochemical Aspects of Pteridines, St.Christoph, Austria
15. Ludwig F, Magnetic nanoparticles in rotating magnetic fields 29/09/2010 German Ferrofluid Workshop, Benediktbeuern
16. Magouroux T, et al., Second Harmonic Imaging Probes for Coherent Bio-Labeling 18/04/2011 Focus on Microscopy 2011, Konstanz, Germany
17. Marotti F, NANOTECHNOLOGICAL TOOLKITS FOR MULTI-MODAL DISEASE DIAGNOSTICS AND TREATMENT MONI 04/05/2011 Symposium on SAFETY ISSUES OF NANOMATERIALS ALONG THEIR LIFE CYCLE, Barcelona (Spain)
18. Mugnier Y, Non linear optical properties of noncentrosymmetric nanocrystals from ensemble measurements and individual inspection 02/07/2010 5th EOS Topical meeting, Advanced Imaging Technique, Engelberg (Switzerland), 2010
19. Mugnier Y, Propriétés optiques non linéaires de nanocristaux non-centrosymétriques à partir de mesures d'ensemble (diffusion Hyper-Rayleigh) et de mesures individuelles (microscopie de Génération de Second Harmonique) 24/08/2010 Journées de la Matière Condensée, JMC12, Troyes (France)
20. Nabiev I, Sukhanova A, Advanced labeling of monoclonal and single-domain antibodies with quantum dots: toward new generation of ultra-small specific nanoprobe. 02/12/2010 7th International Conference on Biomedical Applications of Nanotechnology, Logenhaus, Berlin
21. Nabiev I, Sukhanova A, Bioenergetics with Nanocrystals: Energy transfer between nanostructures and biological supramolecular complexes effects biological function 19/10/2010 5th International Conference on Surfaces, Coatings and Nanostructured Materials (NANOSMAT-5). Reims - France



22. Nabiev I, Bioenergetics with Nanocrystals 15/10/2010 Meeting of French Chemical Society, Reims, France
23. Nabiev I, Nano-Bio Energy Conversion and Vectorisation within the Hybrid Materials Engineered from Colloidal Quantum Dots and Biological Molecules 15/12/2010 Institute of Physics and Chemistry of Materials, University of Strasbourg, France
24. Nabiev I, Nanodiagnostics of Micrometastases 24/11/2010 MINATEC (Micro and Nanotechnologies Innovation Campus), Grenoble, France
25. Nabiev I, Sukhanova A, Bouchonville N, Molinari M, Troyon M, Cohen JHM, "Bioenergetics with nanocrystals". NANAX – 4: Nanoscience with Nanocrystals. International Conference, Munich – Tutzing (Germany), 2010, chaired session
26. Nabiev I, 241st ACS National Meeting "Solar energy conversion and utilization for fuels and energy production" Anaheim, CA (USA), 2011, chaired session
27. Parak WJ, Ion sensing with colloidal nanoparticles 16/11/2010 NanoBioTech Conference, Hotel Eden Palace, Montreux, Switzerland
28. Parak WJ, Ion sensing with colloidal nanoparticles 06/12/2010 Vortrag Physikalisches Kolloquium, Fakultät für Physik, Universität Bielefeld, Germany
29. Parak WJ, Nanotechnology for Diagnostics and Treatment - A Vision 18/11/2010 Vortrag Institute of Bio- and Nanosystems 2, Forschungszentrum Jülich, Germany
30. Prina-Mello A, 08/02/2011 Science Gallery Media Service for Science Foundation Ireland ([www.sfi.ie](http://www.sfi.ie))
31. Prina-Mello A, Nanomedicine as enabling tool for early screening and diagnosis of clinical patholog 02/12/2010 Engineering Ireland, Dublin (Ireland)
32. Prina-Mello A, Implications of Open Innovation in the development of Nanomedicine in Europe 04/10/2010 INTERNATIONAL ACADEMY OF NANOMEDICINE (IANM) 2nd WORLD CONGRESS - Antalya, TURKEY
33. Prina-Mello A, Multiplatform nanodevices for cancer diagnostics 22/06/2011 NanoBioEurope 2011, Cork, Ireland
34. Rakovich A, et al. - Semiconductor Quantum Dots as Light-Harvesting Antennae for Artificial Photosynthesis Applications 28/03/2011 241st ACS Meeting : Solar Energy Conversion and Utilization for Fuels and Energy Production, Anaheim, CA, USA
35. Schrittwieser S, Optical detection of the rotational dynamics of anisotropic magnetic nanoparticles 15/03/2011 DPG Spring Meeting Dresden 2011, Germany
36. Schrittwieser S, Schotter J, Homogeneous biosensor based on optical detection of the rotational dynamics 08/09/2010 Eurosensors XXIV 2010, JKU Linz, Austria
37. Schrittwieser S, Schotter J, Optical detection of the rotational dynamics of anisotropic hybrid nanopart 16/11/2010 NanoBioTech Montreux 2010, Montreux (Switzerland)
38. Schrittwieser, Schotter J, Optical monitoring of rotational dynamics of anisotropic nanoparticles for 02/12/2010 NANOSENS 2010, Vienna, Austria
39. Soulantica K, Synthèse de nanoparticules hétérostructurées Co-X (X= Au, Cu, Fe, Pt, CdSe 17/06/2011 Marseille, (France)
40. Sukhanova A, et al., Energy transfer from quantum dots improves proton pumping and photovoltaic properties of membrane protein bacteriorhodopsin within the QD/bacteriorhodopsin hybrid material 28/03/2011 241st ACS Meeting : Solar Energy Conversion and Utilization for Fuels and Energy Production, Anaheim, CA, USA
41. Rakovich T, APPLICATION OF NANOMATERIALS IN NANOMEDICINE RESEARCH 25/05/2011 Nanomeeting – 2011, Minsk, Belarus
42. Verma N, Volkov Y, Multimodel toxicology and biohazard assessment of nanomaterials and their enabl 02/05/2011 Greener Nano 11, Cupertino CA, USA
43. Volkov Y, "Nano-Barriers" and "Nano-Carriers": Advanced imaging approaches for nanoparticle uptake 25/11/2010 Second Workshop on Optical Imaging, Gottingen (Germany)
44. Volkov Y, Prina-Mello A, 25/05/2011 4th European Conference for Clinical Nanomedicine (CLINAM 2011), Basel (Switzerland)
45. Volkov Y, Prina-Mello A, NAMDIATREAM - an integrated nanotech approach to cancer diagnostics 14/10/2010 European Technology Platform of Nanomedicine – General Assembly, Milan (Italy)
46. Volkov Y, Prina-Mello A, Nanotechnological toolkits for diagnostics and treatment monitoring of c 25/05/2011 Euronanoforum 2011, Budapest (Hungary)
47. Volkov Y, Prina-Mello A, NAMDIATREAM Project - Nanotechnological toolkits for Multi-modal disease 03/11/2010 Cluster Targeted Nanopharmaceuticals and Diagnostics European Union



## Second year (July 2011–June 2012)

48. Alves F, Bode J, Ramos Gomes F, International Workshop: Translational oncology for novel nanoparticle-based diagnostic toolkits 2012, Göttingen
49. Bode J, NAMDIATREAM Winter school - Bioimaging, sensing, and therapeutic applications of nanomaterials 2012, Switzerland
50. Bonacina L, Second harmonic imaging probes for bio-labeling at Progress in Biomedical Photonics, Neuchâtel (CH), November 30th 2011
51. Bonacina L, Wolf JP, Coherent control of biomolecules and imaging using nanodoublers, at CEA/Lethi in Grenoble (France), December 12th 2011 (invited talk at Geneva-Lethi joint workshop, audience ~50 people from academia and public research institutes)
52. Clarke G, et al., Database Development for the Management and Control of Nanomaterials for Biomedical Use, Future of Medicine 2020 Vision, 4 November 2011, TCD Biomedical Sciences Building, Trinity College Dublin (Ireland)
53. Dieckhoff J, et al., Homogeneous bioassays based on the manipulation of magnetic nanoparticles by rotating and alternating magnetic fields – a comparison, May 10th, 2012, INTERMAG 2012, Vancouver, Canada
54. Dieckhoff J, Response of spherical magnetic nanoparticles to rotating magnetic fields, 11th German Ferrofluid Workshop, Benediktbeuren, Germany, September 28th, 2011
55. Gunko Y, Synthesis and chemical modification of nanoparticles for biomedical applications”, 1st Annual World Congress of Nano-S&T, 24th October 2011, World EXPO Center, Dalian (China)
56. Gunko Y, Synthesis and Functionalisation of Nanoparticles for Biomedical Applications, 8th National Congress of Oncology with International Participation, 12th November 2011, Boyana Residence, Sofia (Bulgaria)
57. Jimenez de Aberasturi D, Functionalized nanoparticles for binding ions from biological fluids, Beijing – Conference ChinaNano 2011, 07.-09.09.2011
58. Joulaud C, LeDantec R, Mugnier Y, Bonacina L, Extermann J, Magouroux T, Wolf JP, Galez C Génération de Second-Harmonique d'Oxydes Nanométriques pour l'Imagerie Bio-Médicale”, - OPTIQUE MARSEILLE 2011, 4-7 July 2011, Marseille, France
59. Mafhoud OK, et al., Next frontier in NanoMedicine: Development of Nanotechnological Toolkits for the Multimodal Detection and Monitoring of Disease (NAMDIATREAM). From experimental laboratories to clinical diagnostic practice. Future of Medicine 2020 Vision, 4 November 2011, TCD Biomedical Sciences Building, Trinity College Dublin (Ireland)
60. Magouroux T, Harmonic Nanodoublers for Stem-Cells Tracking, 21-22 June 2012 Swiss Physical Society Zürich (Switzerland)
61. Mardinoglu, Prina-Mello A, “Optimization of functionalized SPIONs as pharmaceutical carriers in magnetizable stent assisted drug targeting applications”, Magnetic Carriers Conference 2012, 24 May 2012, Minneapolis (USA)
62. McCarthy S, Magnetic nanoparticles for medical diagnostics, Seminar at opening of Shuler room in Biosciences building, 24th October 2011, CRANN, Dublin (Ireland)
63. Movia D, NanoImpactNET, From theory to practice - development, training and enabling nanosafety and health research, 28 Feb 2012 UCD, Dublin (Ireland)
64. Nabiev I, SPIE Congres Nanosciences and Nanoengineering, San Diego (USA), 2012, chaired session
65. Parak W. Colloidal nano- and microparticles towards sensing applications Beijing, Conference ChinaNano 2011, 07.-09.09.2011
66. Parak W, Colloidal nano- and microparticles towards sensing applications Lijiang, Conference Molecular Imaging and Nanomedicine Conference 2011, 20.-24.08.2011
67. Passemard S, Staedler D, Juillerat-Jeanneret L, Gerber-Lemaire S, Functionalization of nanoparticles for cancer diagnosis and imaging, 13th Tetrahedron Symposium - Challenges in Bioorganic & Organic Medicinal Chemistry, 26-29 June 2012 Amsterdam (Netherlands)



68. Prina-Mello A, Screening the Cytotoxicity of Single-Walled Carbon Nanotubes Using Novel 3D Tissue-Mimetic Models, NanoImpactNet – QNano Conference, 27th February - 2nd March 2012, Dublin, Ireland.
69. Prina-Mello A, "NAMDIATREAM" Overview and achievements, 5th European Summit for Clinical Nanomedicine, Basel, Switzerland, 7-9 May, 2012
70. Prina-Mello A, "Nanotechnology meets Medicine and moves towards Personalised Diagnostics and Treatment", Department of Physiology Seminar Series, 28th November 2011, University College Cork, Cork (Ireland)
71. Prina-Mello A, EPOSS – MedTech WG meeting report: Brief report of the meeting, ETP-Nanomedicine General Assembly, 18th October 2011, Hospital Universitari de Bellvitge, Barcelona (Spain)
72. Prina-Mello A, High Aspect Ratio Nanoparticles: latest direction and prospective, ELEGI laboratory - seminar presentation, 19th August 2011, Queen Mary's Research Institute, Edinburgh (Scotland)
73. Prina-Mello A, Nanomedicine: diagnostic approaches, Lecture for the MSc in Bioengineering (Trinity College Dublin), 7th March 2012, (TBSI, Dublin)
74. Prina-Mello A, Nanoparticle-cell interactions: in vitro models of cell toxicity, MSc degree in Pharmaceutical and Medical Technologies, 10th November 2011, Trinity College Dublin, School of Pharmacy, School of Medicine and CRANN, Dublin (Ireland)
75. Prina-Mello A, Nanotechnology applied to Healthcare: treatment of human diseases 2, MSc degree in Pharmaceutical and Medical Technologies, 9th November 2011, Trinity College Dublin, School of Pharmacy, School of Medicine and CRANN, Dublin (Ireland)
76. Prina-Mello A, Nanotechnology applied to Healthcare: diagnosis of human diseases, MSc degree in Pharmaceutical and Medical Technologies, 3rd November 2011, Trinity College Dublin, School of Pharmacy, School of Medicine and CRANN, Dublin (Ireland)
77. Prina-Mello A, Nanotechnology applied to Healthcare: monitoring/follow up of human diseases, MSc degree in Pharmaceutical and Medical Technologies, 17th November 2011, Trinity College Dublin, School of Pharmacy, School of Medicine and CRANN, Dublin (Ireland)
78. Prina-Mello A, Nanotechnology contributing to Preventive Medicine How nanotechnologies can contribute to preventive medicine and where are the challenges, ETP-Nanomedicine Annual Forum, 20th October 2011, Hospital Universitari de Bellvitge, Barcelona (Spain)
79. Prina-Mello A, Novel 3D Tissue-Mimetic Model for Biomaterials Evaluation, Bioengineering in Ireland, 27th -28th January 2012, Belfast (Northern Ireland)
80. Prina-Mello A, Regulatory policies on the use of Nanomaterials in Medicine", MSc degree in Pharmaceutical and Medical Technologies, 18th November 2011, Trinity College Dublin, School of Pharmacy, School of Medicine and CRANN, Dublin (Ireland)
81. Prina-Mello A, Round table: future perspectives of nanotools in diagnostics, NMP cluster "Targeted Nano-Pharmaceuticals and Early Diagnostics" meeting focused on Diagnostics, 14th December 2011, Pasteur Institute, Paris (France)
82. Prina-Mello A, The European Technology Platform Nanomedicine Defining future activities of Nanomedicine in Europe, EPOSS General Assembly - MedTech Working Group Meeting, 5th October 2011, Cosmo-Caixa Science Museum, Barcelona
83. Schotter J, Magnetic tools for molecular diagnosis, Europe/NPNT 2011 Joint Workshop on Nano Technology, Hsinchu, Taiwan, December 6th, 2011
84. Schotter J, Optically detected hydrodynamic properties of anisotropic magnetic nanoparticles for real time biosensing 11th German Ferrofluid Workshop, Benediktbeuren, Germany, September 28th, 2011
85. Schrittwieser S, et al., Optically detected rotational dynamics of magnetic nanoparticles for homogeneous immunodiagnosics, May 18th 2012, Biosensors 2012, Cancun, Mexico
86. Schrittwieser S, et al., Optical detection of nanoparticle rotational dynamics as a new approach to homogeneous biosensing, March 1st, 2012, BioNanoMed 2012, Krems, Austria



87. Schrittwieser S, Optical detection of nanoparticle rotational dynamics for application in homogeneous biosensing, Biomedizinische Technik 2011, Freiburg, Germany, September 28th, 2011
88. Staedler D, Passemard S, Magouroux T, Bonacina L, Juillerat-Jeanneret L, Gerber-Lemaire S, Cytocompatibility and Optical Properties assessment of Harmonic Nanoparticles for Biolabelling, 13th Tetrahedron Symposium - Challenges in Bioorganic & Organic Medicinal Chemistry, 26-29 June 2012, Amsterdam (Netherlands)
89. Volkov Y, Advanced imaging at cellular and molecular level, Senior Freshman Molecular Medicine Module, 4 year Undergraduate Medical Curriculum, 24th November 2011, Trinity College Dublin (Ireland)
90. Volkov Y, Application of nanoscience and nanotechnology: the Academic Perspective, Integrated Nanosciences Platform for Ireland Workshop -Introduction to Nanoscience, December 5-9, 201, University of Limerick, Materials and Surface Science Institute (Ireland)
91. Volkov Y, Early diagnostics and treatment monitoring of breast cancer using nanotechnological platforms 5th European Summit for Clinical Nanomedicine, Basel, Switzerland, 7-9 May, 2012
92. Volkov Y, Multimodal nanotech-based toolkits for cancer diagnostics, Biopol'H-IBEC Symposium on Nanomedicine for Healthy Ageing, 19th October 2011, Hospital Universitari de Bellvitge, Barcelona (Spain)
93. Volkov Y, NAMDIATREAM Nanotechnological Toolkits For Multi-Modal Disease Diagnostics and Treatment Monitoring, NMP cluster "Targeted Nano-Pharmaceuticals and Early Diagnostics" meeting focused on Diagnostics, 14th December 2011, Pasteur Institute, Paris (France)
94. Volkov Y, Nanomaterials and Nanomedicine, Senior Freshman Molecular Medicine Module, 4 year Undergraduate Medical Curriculum, 24th November 2011, Trinity College Dublin (Ireland)
95. Volkov Y, Nanoparticle-induced protein citrullination: pathogenic link to autoimmune disease development NanoDiaRA Workshop Nanoparticles in Medicine: Toxicity Methods and Standards 23rd May 2012, EPFL, Lausanne, Switzerland
96. Volkov Y, Nano-reporters and nano-bullets: how nanotechnology advances enable to probe and target human cellular structures?, 8th National Congress of Oncology with International Participation, 12th November 2011, Boyana Residence, Sofia (Bulgaria)
97. Volkov Y, Nanotechnological toolkits for cancer diagnostics and treatment, Information session on 'Horizon 2020' – the new instrument for EU research and innovation funding, 30th November 2011, European Commission Representation in Ireland, Dublin (Ireland)
98. Williams V, SME experience of FP7 grants, Information session on 'Horizon 2020' – the new instrument for EU research and innovation funding, 30th November 2011, European Commission Representation in Ireland, Dublin (Ireland)

### **Third year (July 2012–June 2013)**

99. Artemyev M, Krutokhvostov R, Melnikau D, Oleinikov V, Sukhanova A, Nabiev I, editors. Low-field magnetic circular dichroism in silver and gold colloidal nanoparticles of different sizes, shapes, and aggregation states. SPIE NanoScience+ Engineering; 2012: International Society for Optics and Photonics.
100. Artemyev M, Nabiev I, et al., Low-field magnetic circular dichroism in silver and gold colloidal nanoparticles of different size, shape, and aggregation. SPIE Congress on Nanoscience and Engineering, section Plasmonics: Metallic Nanostructures and Their Optical Properties X, August 2012, San Diego (USA)
101. Bonacina L, CNRS Winter School Nanophysics for Health, Mittelwhir, November 2012: Nonlinear Optics for Imaging and Diagnostic Applications
102. Bonacina L, P3AGI Imaging Workshop, Gottingen, June 2013: Multiphoton imaging and direct DNA photo-interaction with Harmonic Nanoparticles
103. Bonacina L, Photonics West 2013, San Francisco, USA, February 2013: Harmonic nanoparticles for nonlinear bio-imaging and detection



104. Bouchonville N, Molinari M, Sukhanova A, Troyon M, Nabiev I, (2012) Semiconductor quantum dots affect the fluidity of Halobacterium salinarum purple membranes through disruption of bacteriorhodopsin trimer organization. In: Global Congress on Nanosystems in Engineering and Medicine: Nano-Bio-Info Convergence, 10–13 Sep 2012, Incheon, Republic of Korea. INVITED.
105. Clarke G, Prina-Mello A, Mugnier Y, Le Dantec R, Volkov Y Nonlinear optical properties of noncentrosymmetric nanocrystals and second-harmonic microscopy for in-vitro imaging, Winter school Bioimaging, sensing, and therapeutic applications of nanomaterials, March 2013 Switzerland, poster
106. Daineko S, Chistyakov A, Nabiev I, et al., Hybrid heterostructures from organic semiconductors and semiconductor quantum dots for advanced photovoltaic applications. SPIE Congress on Solar Energy and Technology, section Next Generation (Nano) Photonic and Cell Technologies for Solar Energy Conversion III, August 2012, San Diego (USA)
107. Dieckhoff J, Bioassay based on the response of magnetic nanoparticles to rotating magnetic fields, Technical University of Braunschweig, DPG Spring Meeting Dresden 2013, March 11th, 2013 Regensburg,
108. Dieckhoff J, Technical University of Braunschweig, "Homogeneous bioassay based on specifically labelled magnetic nanoparticles in a rotating magnetic field", Winter School NAMDIATREAM, Villars-sur Ollon, Switzerland, March 3rd-6th, 2013 POSTER
109. Dieckhoff J, Technical University of Braunschweig, "Magnetic nanoparticle binding experiments in a rotating magnetic field", 12th German Ferrofluid Workshop, Benediktbeuren, Germany, September 26th-28th, 2012
110. Gerber-Lemaire S, "Chemical Functionalization of Nanomaterials with Small Targeting Agents for Cancer Diagnosis and Imaging", 3rd P3AGI Imaging Workshop, Göttingen, Germany, 12-13 June 2013.
111. Gerber-Lemaire S, Inhibitors of Fibroblast Activation Protein alpha for the labeling of cancer cells, Workshop on Translational Oncology for novel nanoparticle-based diagnostic toolkits. 11 June 2013 Göttingen, Germany
112. Jain N, Atomic Force Microscopy in Nanomedicine, EuroNanoForum 2013, Convention Centre Dublin, 18-20th June 2013 Ireland, commented poster, ENF Poster winner info display on EC and ENF website.
113. Joulaud C, Magouroux T, Hadji R, Extermann J, Le Dantec R, Mugnier Y, Bonacina L, Ciepielewski D, Galez D et Wolf JP Winter school Bioimaging, sensing, and therapeutic applications of nanomaterials, March 2013 Switzerland, poster
114. Ladj R, Valour JP, Mugnier Y, Le-Dantec R, Fessi H, Elaissari A, XX International Conference on Bioencapsulation, Canada - September 2012, "One-pot synthesis and encapsulation of iron iodate ( $\text{Fe}(\text{IO}_3)_3$ ) hybrid nanoparticles via water-in-oil miniemulsion polymer"
115. Ludwig F, Magnetic Nanoparticle Detection: From Homogeneous Bioassays to Imaging, Technical University of Braunschweig, International Scientific CNRS Fall School 2012 on High Sensitivity Magnetometers – Sensors and Applications, October 22th 2012, Branville (France)
116. Ludwig F, Magnetic Nanoparticle Detection: From Homogeneous Bioassays to Imaging, Technical University of Braunschweig, Winter School NAMDIATREAM, March 3rd-6th, 2013 Villars-sur Ollon (Switzerland)
117. Ludwig F, Technical University of Braunschweig, "Homogeneous bioassays based on magnetic nanoparticle" , NAMDIATREAM workshop "Translational oncology for novel nanoparticle-based diagnostic toolkits", Goettingen, Germany, June 11th, 2013
118. Magouroux T, Kiselev D, Kasparian C, Extermann J, Bonacina L, Wolf JP Second Harmonic Imaging Probes for Coherent Bio-Labeling, Focus on Microscopy 2011 Konstanz (Germany) 17/04/2011-20/04/2011
119. Magouroux T, Rogov A, Extermann J, Hoffmann P, Mugnier Y, Le Dantec R, Jaconi ME, Kasparian C, Ciepielewski D, Bonacina L, and Wolf JP High-Speed Tracking of Murine Cardiac Stem Cells by Harmonic Nanodoublers NAMDIATREAM Winterschool 2013 on Bioimaging, sensing, and therapeutic applications of nanomaterials, 03-06 March 2013 Villars (Switzerland)
120. Mahfoud OK, Nanotoolkits for multimodal cancer detection and monitoring EuroNanoForum 2013, Convention Centre Dublin, 18-20th June 2013 Ireland, ENF Poster winner info display on EC and ENF website.



121. Mahfoud OK, Rakovich TY, Jain N, Clarke G, Prina-Mello A, Volkov Y, 15th Institute of Molecular Medicine Annual Meeting – Poster title “Nanotechnological Toolkits for the Multimodal Detection and Monitoring of Disease (NAMDIATREAM). Developing the next generation of cancer diagnostics
122. Mohamed BM, Prina-Mello A, Boyle NT, Byrne F, Schinwald A, Rakovich T, Kieran C Staunton, Omar K Mahfoud, Anthony M. Davies, Ronan Ward, Catherine H. Botting, Ken Donaldson and Yuri Volkov In vivo induction of protein citrullination and auto-antibody formation in mice exposed to nickel nanofibers 15th Institute of Molecular Medicine Annual Meeting -9th November 2012
123. Nabiev I, Hafian H, Sukhanova A, Chames P, Baty D, Pluot M, Cohen JHM, Millot JM (2012) Bi-photon imaging and diagnostics with the ultra-small diagnostic probes engineered from semiconductor nanocrystals and single-domain antibodies. In: Global Congress on Nanosystems in Engineering and Medicine: Nano-Bio-Info Convergence, 10–13 Sep 2012, Incheon, Republic of Korea. INVITED.
124. Nabiev I, Mochalov K, et al., Novel cholesteric materials doped with CdSe/ZnS quantum dots with photo- and electro-tunable circularly polarized emission. SPIE Congress on Nanoscience and Engineering, section Liquid Crystals XVI, San Diego, August 2012.
125. Nabiev I, Sukhanova A, et al., Controlled FRET efficiency in nano-bio hybrid materials made from semiconductor quantum dots and bacteriorhodopsin. SPIE Congress on Nanoscience and Engineering, Section of Biosensing and Nanomedicine II, San Diego, August 2012. INVITED.
126. Nabiev I, Sukhanova A, Oleinikov V, Extension of the spectral range of bacteriorhodopsin functional activity by energy transfer from quantum dots. SPIE Congress on Nanoscience and Engineering, section Nanobiosystems: Processing, Characterization, and Applications V, San Diego, August 2012.
127. Oleinikov VA, Sukhanova A, Nabiev I, Quantum dot-containing polymer particles with thermosensitive fluorescence. SPIE Congress on Nanoscience and Engineering, Section of Biosensing and Nanomedicine II, San Diego, August 2012. INVITED.
128. Passemard S, Staedler D, Juillerat-Jeanneret L, Gerber-Lemaire S, "Functionalization of nanoparticles with small targeting molecules for cancer diagnosis and imaging", Winter School on Bioimaging, sensing and therapeutic applications of nanomaterials, Villars-sur-Ollon, Switzerland, 3-6 March 2013.
129. Passemard S, Staedler D, Učňová L, Juillerat-Jeanneret L, Gerber-Lemaire S, "Convenient synthesis of bifunctional amino-silyl-poly(ethylene glycol) for the coating of iron oxide nanoparticles", Fall meeting of the Swiss Chemical Society, ETH Zürich, Switzerland, 13 September 2012.
130. Prina Mello A, *In Vitro* High Content Screening and Analysis of Nanomaterials for EHS, Nanomedicine, Pharma and Regulatory applications Network of Excellence in Nanomedicine in Italy, University of Rome Tor Vergata, Rome, Italy, 22nd January 2013, Invited talk
131. Prina Mello A, Nanomedicine for Central Nervous System Trinity Centre Institute for Neuroscience 2012 Symposium - 6th November 2012, Invited talk
132. Prina Mello A, Multilayer Personalised Nanomedicine and European Nanomedicine towards Horizon 2020 Nano2013, Rensselaer Polytechnic Institute (RPI) 22nd April 2013 Albany (USA) keynote speaker
133. Prina-Mello A, European Society of Molecular Imaging,. Opening of the ESMI Quantitative Image Analysis and Application Specific Imaging Workshop, 10th -14th September 2012, Dublin (Ireland) hosted and co-organised by Trinity College Dublin
134. Prina-Mello A, Multilayer Nanoparticles and Horizon 2020 Institute of Molecular Medicine, Trinity College Dublin, 20th May 2013, invited talk
135. Prina-Mello A, Multilayer Nanoparticles for Nanomedicine applications, 3rd P3AGI Imaging Workshop, Max-Planck-Institute of Experimental Medicine, 11-12th June 2013 Gottingen, Germany Invited talk
136. Prina-Mello A, Multilayer Nanoparticles in Nanomedicine, Translational Oncology for novel nanoparticle-based diagnostic toolkits, University Medical Centre, 10th June 2013 Gottingen Germany, Invited talk





137. Prina-Mello A, Nanomedicine in Cancer Master in Science in Translational Oncology, Trinity College Dublin, , lecture delivered by titled
138. Prina-Mello A, Nanoparticle Activates Human Platelets: Potential Implication For Nanoparticle Hemocompatibility American Physician Scientists Association (APSA) annual meeting, 26-28th April 2013 Chicago (USA)
139. Prina-Mello A, Rakovich T, Gun'ko Y, Volkov Y, Master, 8 lectures in Science in Molecular Medicine, Trinity College Dublin
140. Rakovich T, Optical Imaging: Bioluminescence and Fluorescence 10th June 2013 Max-Planck-Institute for Experimental Medicine Department of Molecular Biology of Neuronal Signals, Invited talk
141. Rogov A, P3AGI Imaging Workshop, Göttingen (Germany), June 2013: Developing multiphoton multipurpose characterization system for biomaging materials
142. Rogov A, Toward a low temperature synthesis of bismuth ferrite nanoparticles P3AGI Imaging Workshop, Harmonic Nanodoublers for Biolabeling and Stem Cells Tracking, Göttingen (Germany), June 2013:
143. Rogov A, Winter School on Bioimaging, sensing, and therapeutic applications of nanomaterials, Villars-sur-Ollon (Switzerland), March 2013: Developing multiphoton multipurpose characterization system for biomaging materials
144. Schotter J AIT Austrian Institute of Technology GmbH, "Direct protein detection in the sample solution by monitoring rotational dynamics of nickel nanorods", 3rd International Conference on Bio-Sensing Technology, Sitges, Spain, May 14th, 2013
145. Schotter J, AIT Austrian Institute of Technology GmbH, "Homogeneous bioassay based on magnetic manipulation and optical detection of nanorods" , NAMDIATREAM workshop "Translational oncology for novel nanoparticle-based diagnostic toolkits", Göttingen, Germany, June 11th, 2013
146. Schotter J, Direct Protein Detection in the Sample Solution by Monitoring Rotational Dynamics of Nickel Nanorods, AIT Austrian Institute of Technology GmbH, DPG Spring Meeting Dresden 2013, March 11th, 2013 Regensburg
147. Schotter J, Magnetic tools for molecular diagnosis AIT Austrian Institute of Technology GmbH , International Conference on Magnetism 2012, July 9th, 2012 Busan, South Korea.
148. Schotter J, Magnetic tools for molecular diagnosis, AIT Austrian Institute of Technology GmbH, Symposium on NanoBioEngineering and spintronics, Chungnam National University, July 6th, 2012 Daejeon, South Korea,
149. Schotter J, Plasmonic Magnetic detection for advanced Clinical diagnostic, AIT Austrian Institute of Technology GmbH, World Molecular Imaging Congress Workshop title: Nanotechnology in Diagnostic, Monitoring and Treatment of Cancer Advanced in Molecular Imaging, Dublin Convention Centre, September 5th 2012 Dublin, Ireland
150. Schrittwieser S, AIT Austrian Institute of Technology GmbH, "Direct protein detection in the sample solution by monitoring rotational dynamics of nickel nanorods", 3rd International Conference on Bio-Sensing Technology, Sitges, Spain, May 14th, 2013
151. Schrittwieser S, AIT Austrian Institute of Technology GmbH, "Homogeneous biosensor protein detection by monitoring changes in the rotational dynamics of nickel nanorods" BioNanoMed 2013, Krems, Austria, March 13th-15th, 2013
152. Schrittwieser S, AIT Austrian Institute of Technology GmbH, "Homogeneous biosensor protein detection by monitoring changes in the rotational dynamics of nickel nanorods", Winter School NAMDIATREAM, Villars-sur Ollon, Switzerland, March 3rd-6th, 2013
153. Schrittwieser S, Optical detection of the rotational dynamics of anisotropic magnetic Nickel nanorods, AIT Austrian Institute of Technology GmbH, 12th German Ferrofluid Workshop, September 26th, 2012 Benediktbeuren, Germany,
154. Self C, Denting status quo in diagnostics and therapeutics, Selective Antibodies, Winter School NAMDIATREAM, March 3rd-6th, 2013 Villars-sur Ollon (Switzerland)
155. Self C, Selective Antibodies, "Clinically important small molecules, diagnostic challenges and solutions" , NAMDIATREAM workshop "Translational oncology for novel nanoparticle-based diagnostic toolkits", Göttingen, Germany, June 11th, 2013



156. Soulantika K, INSAT, "Co-nanorod heterostructures", Winter School NAMDIATREAM, Villars-sur Ollon, Switzerland, March 3rd-6th, 2013 POSTER
157. Staedler D, Magouroux T, Passemard S, Schneiter GS, Schwung S, Gerber-Lemaire S, Bonacina L, Wolf JP, "New theranostic application of second harmonic BFO nanoparticles as phototherapy tool", Winter School on Bioimaging, sensing and therapeutic applications of nanomaterials, Villars-sur-Ollon, Switzerland, 3-6 March 2013.
158. Sukhanova A, Nabiev I, Imaging Workshop, Göttingen, June 2013.
159. Sukhanova A, Poly S, Shemetov A, Nabiev I, (2012) Quantum dots induce charge-specific amyloid-like fibrillation of insulin at physiological conditions. In: Global Congress on Nanosystems in Engineering and Medicine: Nano-Bio-Info Convergence, 10–13 Sep 2012, Incheon, Republic of Korea. INVITED.
160. Uribarri M, Hormaeche I, Ametzazurra A, Fernández D, Escorza S, IMMUNOASSAY DEVELOPMENT FOR THE QUANTIFICATION OF CANCER BIOMARKERS, Poster presented at NAMDIATREAM Winter School on Bioimaging, sensing, and therapeutic applications of nanomaterials. 3-6 March 2013, Villars-sur-Ollon (Switzerland)
161. Volkov Y, NAMDIATREAM project overview, Translational Oncology for novel nanoparticle-based diagnostic toolkits, University Medical Centre, 10th June 2013 Gottingen Germany, Invited talk
162. Volkov Y, The two sided coin of nanotech: sparkles and traps on the way to serve the mankind University of Marburg, 22nd April 2013, Invited talk
163. Volkov Y, Towards clinical translation: Assay-based applications, 3rd P3AGI Imaging Workshop, Max-Planck-Institute of Experimental Medicine, 11-12th June 2013 Gottingen, Germany Invited talk
164. Volkov Y, 9th Detecting cancer at nanoscale: multimodal nanotech-enabled tools for malignant disease diagnostics International Conference on Nanoscience and Nanotechnologies and Nanotexnolja 12, 3rd -6th July 2012 Thessaloniki (Greece) invited speaker
165. Volkov Y, Building Global Engagements in Research (BGER): Trinity College Dublin, 25-27th February 2013, Swansea University, Wales, Invited talk
166. Volkov Y, Nanotechnological toolkits for cancer diagnostics: benefits and risks International Symposium on Biomedical Engineering and Medical Physics, 10th - 12th October 2012, Riga, Latvia
167. Volkov Y, The two-sided coin of nanotechnologies and nanosafety Moscow Engineering and Physics Institute Public Presentation, 8th October 2012 Moscow, Russia
168. Volkov Y, Prina-Mello A, CAN Venture Forum & Conference 2012, Wednesday 26th September 2012 - The Liberty Stadium, Swansea, Wales. Presentation title "Trinity College Dublin activity and projects"
169. Volkov Y, Prina-Mello A, Nanomaterials' Environmental Health and Safety Assessment: Standard and Innovative solution IDA, Invest in Ireland day, 20th August 2012, CRANN, Dublin (Ireland)
170. Volkov Y, Prina-Mello A, Nanotechnology in Diagnostic, Monitoring and Treatment of Cancer Advanced in Molecular Imaging World Molecular Imaging Congress, 5-9 September 2012, Dublin, Ireland. co-organiser and chairman of the workshop
171. Volkov Y, Prina-Mello A, Rakovich TJ, Mahfoud OK, Carthy SM 7 TCD contributions from NAMDIATREAM Winter School on Bioimaging, sensing, and therapeutic applications of nanomaterials, Villars-sur-Ollon (Switzerland), 3-6 March 2013
172. Chen Y, Low frequency noise in Co/Pd spin valves 12th MMM/Intermag Conference, Chicago, USA., 14-18 January 2013 Invited talk
173. Mugnier Y, Photonics Global Conference, PGC 2012, Singapore, December 2012 Second Harmonic nanocrystals for in-vivo optical imaging



## Fourth year (July 2013–June 2014)

174. Bonacina L, Ciepielewski D, Harmonic Nanoparticles for Nonlinear Imaging And Photo-Interaction SPIE NanoScience and Engineering, August 2014, San Diego (USA)
175. Bonacina L, Coherent nonlinear probes for bio-labelling Laser Laboratorium Göttingen, November 24th, 2010
176. Bonacina L, Harmonic nanoparticles for nonlinear bioimaging and detection SPIE Photonics West, February 2013, San Francisco (USA)
177. Bonacina L, Harmonic nanoparticles for nonlinear imaging and photo-interaction 5th Annual Maastricht Microscopy Meeting (M3), June 2014 Maastricht (The Netherlands)
178. Bonacina L, Multiphoton imaging and DNA photo-interaction with harmonic nanoparticles INSA, Lyon, December 18th, 2013
179. Bonacina L, Multiphoton imaging and DNA photo-interaction with harmonic nanoparticles P3AGI Imaging Workshop, June 2013, Göttingen (Germany)
180. Bonacina L, Nonlinear imaging probes Optical Imaging Workshop - Max Planck Inst. For Experimental Medicine, November 25th-26th, 2010, Göttingen (Germany)
181. Bonacina L, Nonlinear imaging probes, World Molecular Imaging Conference, Spotlight Session: Nanotechnology in Diagnostic Monitoring and Treatment of Cancer Advanced in Molecular Imaging, September 2012, Dublin (Ireland)
182. Bonacina L, Nonlinear optics for imaging and diagnostic applications CNRS Winter School: Nanophysics for health, November 2012, Mittelwhir (France)
183. Bonacina L, Second Harmonic Imaging Probes for Bio-Labeling 5th Int. Conf. from Solid State To Biophysics, June 12th-19th, 2010 - Cavtat (Croatia)
184. Bonacina L, Second harmonic imaging probes for biolabeling Biomedical Photonics Meeting, Neuchatel, November 30th, 2011
185. Bonacina L, Second harmonic imaging probes for biolabeling WE-Heraeus-Seminar Coherent Raman Scattering Microscopy (microCARS2010), Bad Honnef (Germany), October 18th-20th, 2010
186. Bonacina L, Two-photon Microscopy SHG Imaging, Multimodal Molecular Imaging: from high resolution in vitro towards in vivo imaging, July 2014, Göttingen (Germany)
187. Bregoli L, NAMDIATREAM Seminar, 10th February 2014, Dublin (Ireland) "Nanotoxicology: what are the challenges and pitfalls?"
188. Clarke G, Prina-Mello A, Mugnier Y, Le Dantec R, Volkov Y, "Toward a low temperature synthesis of bismuth ferrite nanoparticles" Winter school Bioimaging, sensing, and therapeutic applications of nanomaterials, Switzerland March 2013,
189. Conroy J, Master of Science in Molecular Medicine, 19th February 2014, Dublin (Ireland), Dr. Jennifer presented the following lecture: FLIM methods for Biomedical Studies
190. Conroy J, Master of Science in Molecular Medicine, 20th February 2014, Dublin (Ireland) " Quantum dots for Biomedical Applications"
191. Conroy J, Master of Science in Molecular Medicine, 6th February 2014, Dublin (Ireland), "Raman Spectroscopy for Biomedical Applications"
192. Dieckhoff J, Single-core magnetic markers in rotating magnetic field based homogeneous bioassays and the law of mass action, June 10th-14th, 2014 10th International conference on scientific and clinical applications of magnetic carriers
193. Dieckhoff J, Technical University of Braunschweig, "Magnetic marker based homogenous bioassays utilizing rotating magnetic fields", 58th International Conference on Magnetism and Magnetic Materials (MMM), Denver, USA, November 5th, 2013
194. Efimov A, Mochalov, K., Bobrovsky, A., Agapov, I.I., Chistyakov, A.A., Oleinikov, V.A., and Nabiev, I. Combined scanning probe tomography and optical imaging technique as a novel tool for 3D-characterization of biophotonic and nanophotonic materials. International Workshop "Laser Physics," Prague, Czech Republic, July 2013. INVITED.
195. El Kass M, Houf L, Joulaud C, Le Dantec R, Mugnier Y, Galez C, Fontvieille D, Viboud S, Hadji R, Vincent B, Rouxel D, "Hyper Rayleigh Scattering : a means for investigating the growth mechanism of nanocrystals with quadratic optical properties in reverse micellar solution route synthesis", EOS Annual Meeting 2010, October 26-29 Paris
196. El Kass M, Joulaud C, Houf L, Mugnier Y, Le Dantec R, Hadji R, Vincent B, Djanta-Najombé G, Rouxel D, Fontvieille D, Galez C, "Growth and formation dynamics of acentric dielectric nanoparticles in reverse microemulsions probed by Hyper-Rayleigh Scattering measurements" Colloids and Materials 2011, May 8-11 Amsterdam



197. Elaissari A, Synthesis of Nano-coral like colloidal particles via water-in-oil miniemulsion, 5th Iberian Meeting on Colloids and Interfaces - 26-28 June 2013 Donostia-San Sebastián
198. Esmaeily A, 12th Joint MMM-INTERMAG Conference, 14-18 January 2013, Chicago (USA), "Diameter Modulated Ferromagnetic CoFe Nanowires" poster
199. Extermann J, Harmonic Nanodoublers For Stem Cells Tracking Focus on Microscopy, April 2012, Singapore
200. Frank Ludwig Dynamic magnetic properties of monodisperse single-core magnetic nanoparticle May 5th-8th, 2014 International Magnetism Conference (INTERMAG), Dresden, Germany
201. Gerber-Lemarie S, Chemical Functionalization of Nanomaterials with Small Targeting Agents for Cancer Diagnosis and Imaging, 3rd P3AGI Imaging Workshop, Göttingen, Germany, 12-13 June 2013.
202. Gerber-Lemarie S, Inhibitors of Fibroblast Activation Protein alpha for the labeling of cancer cells, Workshop on Translational Oncology for novel nanoparticle-based diagnostic toolkits. Göttingen, Germany, 11 June 2013.
203. Gun'ko Y, Chiral quantum dots, 2nd International Materials Science & Engineering Conference, 7-9 October, 2013, Las Vegas (USA), invited talk
204. Gun'ko Y, The 5th International Conference on Metamaterials, Photonic Crystals and Plasmonics, 20-23 May, 2014, Singapore, "Chirality in II-VI Quantum Dot Nanostructures" invited talk
205. Jain N, 16th Institute of Molecular Medicine, Dublin (Ireland), 8th November 2013, "Single-molecule force spectroscopy in cancer research" poster
206. Jain N, Master of Science in Molecular Medicine, 6th February 2014, Dublin (Ireland), "Atomic Force Microscopy in Molecular Medicine"
207. Joulaud C, Le Dantec R, Mugnier Y, Galez C, Bonacina L, Extermann J, Kasparian C, Wolf JP, "Second harmonic imaging probes for bio-labeling" Biophotonics and Imaging Graduate Summer School (BIGSS) 2010, 27/08-2/9, The Burren, Co. Clare, Ireland,
208. Joulaud C, Le Dantec R, Mugnier Y, Gnon D, Bonacina L, Extermann J, Wolf JP, Galez C, "Génération de second-harmonique d'oxydes nanométriques pour l'imagerie biomédicale" Journées Nationales des Cristaux pour l'Optique (JNCO), Marseille, 4-7 Juillet 2011,
209. Joulaud C, Magouroux T, Hadji R, Extermann J, Le Dantec R, Mugnier Y, Bonacina L, Ciepielewski D, Galez C, Wolf JP, "Nonlinear optical properties of noncentrosymmetric nanocrystals and second-harmonic microscopy for in-vitro imaging" Winter school Bioimaging, sensing, and therapeutic applications of nanomaterials, Switzerland March 2013
210. Ladj R, One-pot synthesis and encapsulation of iron iodate (Fe(IO<sub>3</sub>)<sub>3</sub>) hybrid nanoparticles via water-in-oil miniemulsion polymer, XX International Conference on Bioencapsulation, Canada - September 2012,
211. Lentijo-Mozo S, Synthesis of air and water stable Cobalt nanorods May 26th-30th, 2014 E-MRS Spring Meeting 14, Lille, FRANCE
212. Mafhoud O, shortlisted for short presentation from poster titled: "Enhancing the sensitivity of cancer biomarker detection using nanomaterial-based approaches: NAMDIATREAM project: Nanotools for Multimodal Cancer Detection and Monitoring". 16th Institute of Molecular Medicine, Dublin (Ireland), 8th November 2013
213. Magouroux T, Harmonic Nanodoublers for Stem-Cells Tracking Swiss Physical Society Zürich (Switzerland) 21/06/2012-22/06/2012
214. Magouroux T, Kiselev D, Kasparian C, Extermann J, Bonacina L, Wolf JP, "Second Harmonic Imaging Probes for Coherent Bio-Labeling" Focus on Microscopy 2011 Konstanz (Germany) 17/04/2011-20/04/2011
215. Magouroux T, Rogov A, Extermann J, Hoffmann P, Mugnier Y, Le Dantec R, Jaconi ME, Kasparian C, Ciepielewski D, Bonacina L, Wolf JP, "High-Speed Tracking of Murine Cardiac Stem Cells by Harmonic Nanodoublers" NAMDIATREAM Winterschool 2013 on Bioimaging, sensing, and therapeutic applications of nanomaterials Villars (Switzerland), 3-6 March 2013.
216. Mochalov K, Bobrovsky A, Efimov A, Oleinikov V, Linkov P, Samokhvalov P, Sukhanova A, and Nabiev I, Circularly polarized emission from cholesteric liquid crystal material doped with quantum dots can be controlled both optically and electrically. International Workshop "Laser Physics," Prague, Czech Republic, July 2013. INVITED.
217. Monzon LA, MiMe (Materials in medicine) 8-11 October 2013, Faenza (Italy), "Electrosynthesis of multisegmented nanowires".
218. Movia D, 16th Institute of Molecular Medicine, Dublin (Ireland), 8th November 2013, "Gold Nanoboxes (AuNBs) as Multifunctional Nanotools for Companion Diagnostic" poster
219. Mugnier Y, Non linear optical properties of noncentrosymmetric nanocrystals from ensemble measurements (Hyper-Rayleigh Scattering) and individual inspection (SHG microscopy), 5th EOS Topical meeting, Advanced Imaging Techniques, Engelberg, 29 June-2 July 2010



220. Mugnier Y, Propriétés optiques non linéaires de nanocristaux non-centrosymétriques à partir de mesures d'ensemble (diffusion Hyper-Rayleigh) et de mesures individuelles (microscopie de Génération de Second Harmonique), Journées de la Matière Condensée, JMC12, Troyes, Aout 23-27, 2010
221. Mugnier Y, Second Harmonic (SH) nanocrystals for in-vivo optical imaging, Interdisciplinary workshop of Savoy University, Biopark d'Archamps, May 23rd, 2012
222. Mugnier Y, Second Harmonic (SH) nanocrystals for multimodal imaging, early diagnostics and theranostic applications, Invited Seminar, Jean-Lamour Institute, Nancy, February 13th, 2014
223. Mugnier Y, Second Harmonic nanocrystals for in-vivo optical imaging Photonics Global Conference, PGC 2012, December 2012, Singapore
224. Nabiev I, SPIE Photonics West International Conference, San Francisco, CA (USA), 2014, chaired session
225. Passemard S, Staedler D, Juillerat-Jeanneret L, Gerber-Lemaire S, "Functionalization of nanoparticles with small targeting molecules for cancer diagnosis and imaging", Winter School on Bioimaging, sensing and therapeutic applications of nanomaterials, Villars-sur-Ollon, Switzerland, 3-6 March 2013.
226. Passemard S, Staedler D, Juillerat-Jeanneret L, Gerber-Lemaire S, Functionalization of nanoparticles for cancer diagnosis and imaging, 13th Tetrahedron Symposium - Challenges in Bioorganic & Organic Medicinal Chemistry, 26-29 June 2012, Amsterdam, Netherlands.
227. Passemard S, Staedler D, Sonogo G, Loup J, Juillerat-Jeanneret L, Gerber-Lemaire S, Functionalized nanomaterials for cancer diagnosis, Fall Meeting of the Swiss Chemical Society, September 6, 2013, EPFL, Switzerland.
228. Passemard S, Staedler D, Sonogo G, Loup J, Juillerat-Jeanneret L, Gerber-Lemaire S, "Functionalized nanoparticles for the targeting of cancer cells", RICT 2013, 3-7 July 2013, Nice, France. S. Passemard was awarded the best poster presentation at this occasion.
229. Passemard S, Staedler D, Učňová L, Juillerat-Jeanneret L, Gerber-Lemaire S, "Convenient synthesis of bifunctional amino-silyl-poly(ethylene glycol) for the coating of iron oxide nanoparticles", Fall meeting of the Swiss Chemical Society, ETH Zürich, Switzerland, 13 September 2012.
230. Prina-Mello A, 16th Institute of Molecular Medicine, Dublin (Ireland), 8th November 2013, "Investigation of autoimmune responses to engineered nickel nanomaterials in in vitro and in vivo systems" poster
231. Prina-Mello A, 16th Institute of Molecular Medicine, Dublin (Ireland), 8th November 2013, "Nanomedicine applied to Translational Oncology: a future perspective to cancer treatment" poster
232. Prina-Mello A, 7th International NANOTOX conference, 22-29 April 2014, Antalya (Turkey)
233. Prina-Mello A, AMBER review meeting, 21st May 2014, Dublin (Ireland),
234. Prina-Mello A, AMCARE review meeting, 29-30 April 2014
235. Prina-Mello A, Bionanomed 2014, 26-29 February 2014, Krems (Austria), "Safe-by-design approach for the development of multifunctional carriers for diagnostic and theranostic applications".
236. Prina-Mello A, Celtic Alliance for Nanohealth Venture Forum, Dublin (Ireland), 17th October 2013, Nanomedicine session chair
237. Prina-Mello A, CLINAM, 22-26 June 2014, Basel (Switzerland) "Gold nanoparticles as carrier for internalization into lung adenocarcinoma cells: 3 tiered approach for therapeutic applications" invited talk
238. Prina-Mello a, EPFL, 28th May 2014, Lausanne (Switzerland), Mr Davide Staedler PhD degree, thesis examination, as part of the examination Jury.
239. Prina-Mello A, ETP NANOMEDICINE General Assembly, 30th October -1st November 2013, Dr. chaired the following session and presented the NANOMEDICINE Characterization, Toxicology working group"
240. Prina-Mello A, ETP-Nanomedicine, 3-4 March 2014, Brussels (Belgium), ETP-N Executive meeting.
241. Prina-Mello A, Euronanomed II Workshop and Training, 29-30 January 2014, Dusseldorf (Germany), "Ethics and Safety Issues in Nanomedicine" invited talk
242. Prina-Mello A, Inhaled Particle XI, British Occupational Health and Science biannual events, 23 - 25 September 2013, Nottingham (UK), title: "Investigation of autoimmune responses to engineered nickel nanofibers in vitro and in vivo approach. invited talk
243. Prina-Mello A, Master of Science in Bioengineering, 7th March 2014, Dublin (Ireland), "Nanomaterials and Devices for Bioengineering"
244. Prina-Mello A, Master of Science in Molecular Medicine, 19th February 2012, Dublin (Ireland), "Nanoethics".
245. Prina-Mello A, Master of Science in Molecular Medicine, 20th February 2012, Dublin (Ireland), " Multi-functional nanomaterials for diagnostics and therapy".



246. Prina-Mello A, Master of Science in Molecular Medicine, 20th February 2012, Dublin (Ireland), "Nanotechnological applications in oncology"
247. Prina-Mello A, Master of Science in Molecular Medicine, 6th February 2012, Dublin (Ireland), "Introduction to Nanotoxicology".
248. Prina-Mello A, Master of Science in Pharmaceutical and Medical Nanotechnology, 14th March 2014, Dublin (Ireland) "Nanoparticle-cell interactions: in vitro models of cell toxicity".
249. Prina-Mello A, Master of Science in Pharmaceutical and Medical Nanotechnology, 21st February 2014, Dublin (Ireland), " Nanotechnology applied to Healthcare: monitoring/follow up of human diseases".
250. Prina-Mello A, Master of Science in Pharmaceutical and Medical Nanotechnology, 28th February 2014, Dublin (Ireland), "Regulatory policies on the use of Nanomaterials in Medicine"
251. Prina-Mello A, Master of Science in Translational Oncology, 15th February 2014, Dublin (Ireland), "Nanomedicine and cancer".
252. Prina-Mello A, Medical Technology, R&D Funding Opportunities, Joint event organized by Enterprise Ireland and IMDA, 18th September 2013, Galway (Ireland)" Opportunities in the Nanomedicine area" invited talk
253. Prina-Mello A, NANO futures Steering Committee Meeting, Brussels (Belgium), 12th September 2013,:"Nanomedicine perspectives within H2020".
254. Prina-Mello A, Nanomedicine at European level Current Challenges Facing Inorganic Nanoparticles in Medicine and Industry Conference + Working Session, 27-28 September 2013, Bern (Switzerland), invited talk
255. Prina-Mello A, Nanomedicine, AMCARE meeting, 22nd January 2014, Stuttgart (Germany), "Nanomaterial biocompatibility assessment and EHS evaluation".
256. Prina-Mello A, NanotechItaly 2014, Venice (Italy) 26-28 November 2014, invited talk titled: "Multilayered Nanoparticles for Nanomedicine Applications".
257. Prina-Mello A, Second International School-Conference "Applied Nanotechnology & Nanotoxicology", Baikal, Russia -10-19 August 2013,: Multi-layered nanotechnology for nanomedicine: overview. invited talk titled
258. Prina-Mello A, Specialised Seminar at EPFL Lausanne 29th August 2013, , title of the talk:" Nanotechnology for Nanomedicine: overview" invited speaker
259. Prina-Mello A, TP3 NAMDIATREAM management meeting, 18th March 2014
260. Rakovich T, Master of Science in Molecular Medicine, 19th February 2014, Dublin (Ireland),"Principles and applications of FRET"
261. Remmer H, Suitability of magnetic single- and multi-core nanoparticles to detect protein binding with dynamic magnetic measurement techniques, June 10th-14th 2014, 10th International conference on scientific and clinical applications of magnetic carriers
262. Samokhvalov P, Linkov P, Nabiev I, Photoluminescence quantum yield of CdSe-ZnS/CdS/ZnS core-multishell quantum dots approaches 100% due to enhancement of charge carrier confinement. SPIE Photonics West International Conference, February 2014, The Moscone Center San Francisco, California, USA
263. Schotter J, AIT Austrian Institute of Technology GmbH, "Homogeneous breast cancer biomarker assay based on optical detection of the rotational dynamics of magnetic nanorods", 13th German Ferrofluid Workshop, Benediktbeuren, Germany, September 25th, 2013
264. Schotter J, Homogeneous breast cancer biomarker detection by optically measuring the rotational dynamics of magnetic nanorods 14th March 17th, 2014 German Ferrofluid Workshop, Ilmenau, Germany
265. Schrittwieser S, Homogeneous breast cancer biomarker detection by optically measuring the rotational dynamics of magnetic nanorods March 27th, 2014 BioNanoMed 2014, Krems, Austria
266. Schrittwieser S, Protein biomarker detection by a homogeneous label-free method based on rotational dynamics of hybrid magnetic nanorods, June 10th-14th 2014, 10th International conference on scientific and clinical applications of magnetic carriers
267. Schrittwieser S, Protein biomarker detection by a homogeneous label-free method based on rotational dynamics of hybrid nanoparticles March 31st-April 1st 2014, 2nd Austrian Biomarker Symposium on Early Diagnostics 2014
268. Solovyeva D, Lukashov E, Linkov P, Samokhvalov P, Dayneko S, Zaitsev S, Oleinikov V, Shemetov A, Sukhanova A, Nabiev I, Chistyakov AA, Photovoltaic cells engineered from purple membranes of Halophilic bacteria and semiconductor quantum dots. International Workshop "Laser Physics," Prague, Czech Republic, July 2013. INVITED.
269. Soulantica K, Nano-objets Multifonctionnels à base de Co préparés par chimie Organometallique Réunion Thématique Nano-hybrides (GDR Nanoalliages), Paris, France January 20th-21st, 2014



270. Soulantica K, Synthesis of metallic magnetic nanorods protected by noble metal shell BiOS. SPIE photonics conference, San Francisco, USA
271. Soulantica K, Université de Toulouse, INSA, UPS, LPCNO, and CNRS, LPCNO, "Cobalt-based Multifunctional Nano-objects Prepared by the 'Organometallic' Route", The 2nd Japan-France Coordination Chemistry Symposium 2013, Nara City, Japan, November 25th, 2013
272. Staedler D, Magouroux T, Passemard S, Schneiter GS, Schwung S, Gerber-Lemaire S, Bonacina L, Wolf JP, "New theranostic application of second harmonic BFO nanoparticles as phototherapy tool", Winter School on Bioimaging, sensing and therapeutic applications of nanomaterials, Villars-sur-Ollon, Switzerland, 3-6 March 2013.
273. Staedler D, Passemard S, Magouroux T, Bonacina L, Juillerat-Jeanneret L, Gerber-Lemaire S, "Cytocompatibility and Optical Properties assessment of Harmonic Nanoparticles for Biolabelling", 13th Tetrahedron Symposium - Challenges in Bioorganic & Organic Medicinal Chemistry, Amsterdam, Netherlands, 26-29 June 2012.
274. Staedler D, Passemard S, Schneiter GS, Sonogo G, Loup, Juillerat-Jeanneret L, Gerber-Lemaire S, "Evaluation of a new small organic inhibitor of prolyl-endopeptidases for nano-theranostic applications", Fall Meeting of the Swiss Chemical Society, September 6, 2013, EPFL, Switzerland and RICT 2013, 3-7 July 2013, Nice, France.
275. Sukhanova A, Bouchonville N, Le Cigne A, Molinari M, Linkov P, Samokhvalov P, Oleinikov V, Nabiev I, Biophotonics with nano-bio hybrid material with controlled FRET efficiency engineered from quantum dots and membrane protein bacteriorhodopsin. International Workshop "Laser Physics," Prague, Czech Republic, July 2013. INVITED.
276. Sukhanova A, Rakovich YuP, Oleinikov VA, Nabiev I, Large nonlinear and linear optical responses in a hybrid nanobiomaterial engineered from bacteriorhodopsin and semiconductor quantum dots. SPIE Photonics West International Conference, February 2014, The Moscone Center San Francisco, California, USA
277. Volkov Y, 5th Annual International Symposium "Biosecurity and Biosafety: future trends and solutions" 2-4th April 2014, Cusani Palace, Milan (Representative Location of NATO Rapid Reaction Corps Command) "Nanotools for advanced diagnostics and therapy: benefits and safety concerns" invited talk
278. Volkov Y, 7th International NANOTOX conference, 22-29 April 2014, Antalya (Turkey) "Multimodal nanotech-enabled approaches in cancer diagnostics" invited talk
279. Volkov Y, Master of Science in Molecular Medicine, 9th January 2014, "Introduction to nanomedicine"
280. Volkov Y, Master of Science in Molecular Medicine, 9th January 2014, "Nanomaterials"
281. Volkov Y, Nano World Cancer Day, Dublin, Ireland, 31st January 2014 "Cancer nanomedicine projects in Ireland: nanotechnological solutions for molecular and cellular diagnostics"
282. Volkov Y, Nanotechnological approaches in medicine, Orel Medical University, Orel, Russia, 30 November 2014
283. Volkov Y, Official opening days of the EU-Russia Year of Science, Moscow, 26-29 November 2014, MEFI Institute venue, invited talk: "Key aspects of nanosafety in medicine"
284. Volkov Y, Official opening days of the EU-Russia Year of Science, Moscow, 26-29 November 2014, MEFI Institute venue, invited talk: "Nanotech applications for molecular and cellular diagnostics"
285. Volkov Y, Prina-Mello A, Quality Nano General Assembly, 25th March 2014, Dublin (Ireland)
286. Volkov Y, Second International School-Conference "Applied Nanotechnology & Nanotoxicology", Baikal, Russia -10-19 August 2013, invited talk titled: "Nano-tools for advanced biomedical imaging"
287. Volkov Y, Second International School-Conference "Applied Nanotechnology & Nanotoxicology", Baikal, Russia -10-19 August 2013, Prof. Yuri, chairman of session and invited talk titled: "Molecular supermarkets, nanobullets and autoimmune diseases: the multi-faceted challenges in Nanomedicine".
288. Volkov Y, XXI International Conference on Cardiology „Progress in diagnosis and treatment of heart, lung and vessel diseases" 29-30 May 2014, Zabrze, Poland. "Delivering safe nanotechnological solutions for advanced diagnostics and therapy: the experience of two multi-centre European consortia" invited talk
289. Wolf JP, Optical Strategies for Enhancing Sensing, Imaging, Communication, and Energy Conversion NATO ERICE SCHOOL 2013 « Biosensing Instrumentation », July 4-19, 2013 Erice (Italy)
290. Wolf JP, Quantum control of biomolecules and imaging using nanodoublers Conference: Physics of Biology, 26-28 November 2013, Geneva



## Special Events

### Organized workshops, schools and seminars

#### Organized events for stakeholders and public engagement:

1. Hofman H " Superparamagnetic Nanoparticles for Medical Application, (22nd February 2012, TCD, Dublin)
2. Prina-Mello A "CRANN Nanoscience Institute and Focus in Cancer" Trinity College - Cancer Town Hall, (Dublin), (February 2012)
3. Volkov Y EU Funding Champion, Enterprise Ireland Royal Hospital Kilmainham (Dublin) 8th June 2012

#### Organized Workshops:

1. Workshop "Nanoscience: Chemistry and Physics Behind Supramolecular Science", at Chemistry and Physics behind energy transfer from nanostructures to bio-supramolecular photosensitive complexes., organized by College de France and Fundación Botín, San Sebastian – Donostia (Spain), 16 July 2010.
2. Workshop "Nanotechnology in Diagnostics, Monitoring and Treatment of Cancer Advanced in Molecular Imaging" within the fifth annual meeting of the World Molecular Imaging Congress (WMIC), Dublin (Ireland), 5–8 September 2012
3. International Workshop "Laser Physics", Prague (Czech Republic), July 2013.
4. Winter School "Bioimaging, sensing and therapeutic applications of nanomaterials", Villars-sur-Ollon (Switzerland), 3–6 March 2013
5. Workshop 7 "Nanomedicine: Technology Platforms and Breakthrough Projects" at Euronanoforum 2013 Conference, Dublin (Ireland), 18-20 June 2013
6. Workshop 8 "Market Strategies in the Medical Device Industry" " at Euronanoforum 2013 Conference, Dublin (Ireland), 18-20 June 2013
7. European Society for Molecular Imaging "Quantitative Image Analysis and Application Specific Imaging Workshop" Trinity College Dublin also hosted and co-organised a European Society for Molecular Imaging workshop (ESMI PRIMA Curriculum, 10-14th September 2012
8. Translational Oncology for novel nanoparticle-based diagnostic toolkits, University Medical Centre, Gottingen Germany. Prof. Stammer, Prof. Alves, Prof. Volkov and Dr. Prina-Mello were among the Max Plank Institute organising committee of the translational oncology workshop which took place on the 10th June 2013.
9. Nikon Instruments will present a stand at the conference MiFoBio 2014 (Seignosse, France, 4th -10th October 2014) also disseminating NAMDIATREAM results.
10. UniGE and Nikon: participation to the EPHJ Medtech event at Geneva Palaexpo on June 18th 2014 for disseminating NAMDIATREAM TP3 highlights, with a focus on imaging activities.
11. UdS: Local organizer of a one-day workshop "La dispersion des poudres et suspensions" in collaboration with the Malvern Company. 30 participants, Annecy, 2012, June 7th
12. A Rogov (UniGE) participated at the FAMELAB science vulgarization contest at CERN, video footage at: <http://cds.cern.ch/record/1692591>
13. Science popularization: Public debate, science and citizen: "Nanotechnologies, quel Avenir?", Chambéry (19/01/2012), [www.scienceactions.asso.fr](http://www.scienceactions.asso.fr) with D.Bloch, P. Boisseau, N. Farouki, Y. Mugnier et F. Vacherand





## Industrial presentations, workshops and trade fairs

1. Workshop at University of Bristol (“Precision Microfluidic Applications and Solutions”); 12th December 2013. Workshop focused on applications of Cellix’s products and NAMDIATREAM project pipeline products.
2. 6th Annual Lab-on-a-chip European Congress, Berlin, Germany; 10th – 11th March 2014. Trade booth where NAMDIATREAM chip, results, and concept were presented. Main highlight: dissemination of flow focusing abilities and integration of sensors on-chip.
3. Siemens IVD (in-vitro diagnostics) conference; invite-only. Palo Alto, CA, USA; 9th – 11th April 2014. Trade booth where NAMDIATREAM chip, results, and concept were presented. Dissemination of flow focusing abilities and integration of sensors on-chip for diagnostic applications. NOTE: Attended by top level executives at Siemens including their CEO of healthcare sector.
4. 64th Annual Meeting of the British Microcirculation Society Annual Conference, Bristol, UK; 10th – 11th April 2014. Trade booth where NAMDIATREAM chip, results, and concept were presented.
5. Advances in Optofluidics: Integration of Optical Control and Photonics with Microfluidics; Dublin Ireland; 24th – 25th April 2014. Trade booth where NAMDIATREAM chip, results, and concept were presented with integrated microfluidics capabilities.
6. Flow14 (1st annual microfluidics & Nanofluidics conference), Twente, The Netherlands; 18th – 21st May 2014. Trade booth where NAMDIATREAM chip, results, and concept were presented.
7. 2nd Flow Assay Workshop, in partnership with Cellix’s distributor tebu-bio; Le Perray en Yvelines, Paris, France; 5th – 6th June 2014. Workshop dedicated to Cellix’s products and hosted by Cellix’s distributor in France, tebu-bio.



## Acknowledgements

The Project Coordinator Prof. Yuri Volkov and the Deputy Coordinator Dr. Adriele Prina-Mello would like to acknowledge the efforts of all 22 partners involved in the NAMDIATREAM consortium.

Special thanks to the Technology Platform leaders for their dedication and hard work at the core activities of the NAMDIATREAM project.

We express our sincere gratitude to the Coordination Team: Greta Kerins (TCD), Tommaso Foglia (INNOVA), Silvia Molinari (INNOVA), PierLuigi Franceschini (INNOVA) and Federica Marotti (INNOVA).

We would like to personally thank Dr. Darragh Crotty and Dr. Lisa Bregoli for the endless work and dedication to produce this booklet.

We would also like to thank the proof reading and contribution provided by Christiaan Koop, Communications and Marketing Manager of the World Molecular Imaging Society, Drs Liam Brown, Sergio Fernandez-Ceballos, Philip Cheasty, Ciaran Duffy, Coordinator of the Organising Committee of the EuroNanoForum 2013 and National Contact Points for Enterprise Ireland FP7 Team, respectively.

## Funding

This work was supported by the European Commission under the Seventh Framework Programme focused on Nanosciences, Nanotechnologies, Materials and New Production Technologies (NMP), as the NAMDIATREAM project (FP7 NMP4-LA-2010-ref. 246479).